

MFJ

Legal Limit IntelliTuner™ Automatic Antenna Tuner

Model MFJ-998



INSTRUCTION MANUAL

CAUTION: Read All Instructions Before Operating Equipment

MFJ ENTERPRISES, INC.

300 Industrial Park Road
Starkville, MS 39759 USA
Tel: 662-323-5869 Fax: 662-323-6551

DISCLAIMER

Information in this manual is designed for **user purposes only** and is *not* intended to supersede information contained in customer regulations, technical manuals/documents, positional handbooks, or other official publications. The copy of this manual provided to the customer will *not* be updated to reflect current data.

Customers using this manual should report errors or omissions, recommendations for improvements, or other comments to MFJ Enterprises, 300 Industrial Park Road, Starkville, MS 39759. Phone: (662) 323-5869; FAX: (662) 323-6551. Business hours: M-F 8-4:30 CST.

Contents

THE BASICS

Introduction.....	1
Features.....	2
Specifications.....	3
Transceiver Protection.....	4
Amplifier Protection.....	4
Fast Start.....	5
Front Panel.....	6
SWR/Wattmeter.....	6
Analog Meter Zero Scale Adjustment.....	6
Analog Meter Full Scale Adjustment.....	7
LCD Display.....	7
LCD Contrast Control.....	7
ANT Button.....	7
MODE Button.....	7
C-UP and C-DN Buttons.....	7
L-UP and L-DN Buttons.....	7
TUNE Button.....	8
StickyTune™.....	8
Automatic/Semi-Automatic Tuning Mode.....	8
POWER Button.....	8
Back Panel.....	10
Amp Enable In.....	10
Amp Enable Out.....	10
Power.....	10
Radio Interface.....	10
Jumper JP1.....	11
Serial Port.....	13
Transmitter.....	13
Ground.....	13
Wire.....	13
Antenna 1.....	13
Antenna 2.....	13
Installation.....	14
SWR/Wattmeter.....	14

THE MENUS

Main Mode Menus.....	15
Digital Wattmeter Menu.....	15
Power Bar Meter Menu.....	15
SWR Bar Meter Menu.....	16
L-Network Menu.....	16

Tuner Indicators	17
Antenna	17
Radio Interface	17
Amp Relay Enable	17
Memory	18
LC Limit	18
Auto Range	18
Auto/Semi	18
StickyTune	18
Setup Mode Menus	19
Target SWR Menu	19
Auto Tune SWR Menu	19
Amp Bypass SWR Menu	19
Meter Range Menu	20
Peak Hold Menu	20
Memory Menu	20
IntelliTune Menu	21
SWR Beep Menu	21
Beep Menu	21
Refresh Menu	21
Radio Interface Menu	21
Push Tune <0.5s Menu	22
LC Limit Menu	22

OPERATION

Manual Tuning	22
Morse Code and Beeps	23
Transceiver Foldback	24
Grounding Hints	25
Antenna System Hints	25
Coaxial Cable Selection	25
Location	25
Matching Problems	26

APPENDICES

Resetting the Tuner	27
Factory Defaults	27
Disable Radio Interface	28
Delete Entire Antenna Memory	28
Delete Antenna Memory Bank	28
Total Reset	28
Self Test	29
Power-Down Circuit Test	30
Relay Test	30
Analog Meter Calibration	30
SWR Bridge Calibration	31
Frequency Counter Calibration	32

Alinco Radio Interface.....	33
Connections	33
Operation	33
Icom Radio Interface.....	34
Connections	34
Operation	34
Kenwood Radio Interface	35
Connections	35
Operation	35
Yaesu Radio Interface/MFJ-5114Y	36
Connections for FT-100.....	36
Operation for FT-100.....	36
Connections for FT-450.....	37
Operation for FT-450.....	37
Connections for FT-857 or FT-897.....	38
Operation for FT-857 or FT-897.....	38
Connections for FT-950.....	39
Operation for FT-950.....	39
Yaesu Radio Interface/MFJ-5114Y3	40
Connections for FT-1000MP series of radios.....	40
Operation for FT-1000MP series of radios.....	40
Connections for FT-2000 series of radios.....	40
Operation for FT-2000 series of radios.....	41
Connections for FTDX-9000 series of radios.....	41
Operation for FTDX-9000 series of radios.....	42
Yaesu Radio Interface/MFJ-5114Y4	42
Connections for FT-2000 series of radios.....	42
Operation for FT-2000 series of radios.....	42
In Case of Difficulty	43
Technical Assistance.....	43
List of Accessories.....	43
Circuit Block Diagram.....	44

FIGURES

Figure 1. Typical Installation Block Diagram	6
Figure 2. MFJ-998 Front Panel.....	6
Figure 3. Mode Button Flow Chart and Button Action	9
Figure 4. MFJ-998 Back Panel	10
Figure 5. Radio Interface Connector.....	10
Figure 6. Alinco Interface Cable.....	11
Figure 7. Icom Interface Cable	11
Figure 8. Kenwood Interface Cable.....	12
Figure 9. Yaesu Interface Cable (FT-100/-450/-857/-897/-950)	12
Figure 10. Yaesu Interface Cable (MP/2000/9000 series).....	13
Figure 11. Yaesu Interface Cable (FT-2000 series).....	13
Figure 12. SWR/Wattmeter	14
Figure 13. Power Bar Meter (High Range).....	16
Figure 14. Power Bar Meter (Low Range)	16
Figure 15. SWR Bar Meter	16
Figure 16. Main Mode Menus Display	17

Figure 17. Tuner Indicators..... 18
Figure 18. Power-On Operations 27
Figure 19. MFJ-998 Circuit Block Diagram..... 44

TABLES

Table 1. Memory Resolution 20
Table 2. Tuner Beeps 24
Table 3. Failure Messages..... 29

The Basics

Introduction

The MFJ-998 *IntelliTuner*[™] is a comprehensive **Full Legal Limit** automatic antenna tuning center with an internal SWR/wattmeter and an antenna switch for two antennas. The MFJ-998 lets you rapidly tune almost any unbalanced or single-wire antenna automatically. Balanced feedlines may be used with an MFJ-912 1.5 kW 4:1 balun connected to the MFJ-998 antenna output.

The MFJ-998 includes MFJ's *Amplifier Bypass Control*[™]. This exclusive MFJ antenna tuner feature fully protects your amplifier during tuning, and will even take your amplifier off-line should the SWR increase above a user-defined pre-set limit.

MFJ's exclusive *InstantRecall*[™], *IntelliTune*[™] and *AdaptiveSearch*[™] algorithms give you fast automatic tuning with more than 20,000 non-volatile *VirtualAntenna*[™] memories. Each of the two antenna outputs has four banks of memory; and each memory bank has over 2500 non-volatile memories for tuner settings.

The MFJ-998 *IntelliTuner*[™] includes a highly efficient switched-L network with wide matching capability, 1.8 to 30 MHz coverage, cross-needle power meters, backlit LCD display, a radio interface port, and heavy-duty 16 amp/1000 volt relays. It is rated at 1500 watts SSB/CW and will match impedances from 12 to 1600 ohms (SWR up to 32:1).

A maximum of 256 values of inductance and 256 values of input capacitance or 64 values of output capacitance are available. This provides a total of 81,664 L/C tuning combinations. The nominal tuning ranges are 0 to 24 μ H and 0 to 3900 pF (input) or 0 to 970 pF (output). And once a match is found, the matching network values can be displayed so you may design your own fixed matching network if desired.

The MFJ-998 *IntelliTuner*[™] learns and remembers. When you transmit, it automatically adjusts for minimum SWR and remembers the frequency and tuner settings, safely stored in non-volatile memory. The next time you operate on that frequency (or close to it) and antenna, the tuner settings are instantly restored and you're ready to operate in milliseconds. Each of the two switched antenna outputs has four banks of memory, which can learn and remember more than 2500 frequencies and tuner settings per bank.

When you key your transmitter, MFJ's *InstantRecall*[™] checks its memory to see if you have operated on that frequency before. If so, tuning is instantaneous and you're ready to operate. If not, MFJ's *IntelliTune*[™] algorithm (based on MFJ's famous SWR Analyzer technology) kicks in. It measures the complex impedance of your antenna. Next it calculates the components needed and instantly snaps them in. Finally, it fine-tunes to minimize SWR, and you're ready to operate – typically in a fraction of a second.

If the antenna impedance is not within the tuner's measurement range, MFJ's *AdaptiveSearch*[™] algorithm goes into action. Frequency is measured and relevant components values are determined. Only those values are searched for fast tuning. If it still cannot find a match, the search is performed again using a different search pattern.

The target tuned SWR can be set to 1.0 to 2.0. The minimum power to tune is approximately five watts, with maximum SWR tuning accuracy occurring at tuning power levels of 10-30 watts. Manual tuning is also available for "touching up" the tuning if desired.

Like all MFJ's *IntelliTuners*[™], the MFJ-998 supports radio tuner interfaces that are compatible with Alinco EDX-2 tuner, Icom AH-3 and AH-4 tuners, Kenwood AT-300 tuner, Yaesu FC-30 tuner, and Yaesu FH-1 and FH-2 remote controls. Optional interface cables MFJ-5114A (for Alinco), MFJ-5114I (for Icom), MFJ-5114K (for Kenwood), and MFJ-5114Y/Y3/Y4 (for Yaesu) are available from MFJ Enterprises, Inc.

The MFJ-998 tuner enters a "sleep" mode when idle and when no transmit signal is present, turning off the microprocessor clock to avoid the generation of spurious signals.

Features

- Automatically matches antennas from 12 to 1600 ohms impedance (SWR up to 32:1)
- Handles 1500 watts SSB/CW
- Tunes in less than 20 seconds, usually less than 5 seconds
- *Amplifier Bypass Control*[™] automatically protects your amplifier during tuning and external high SWR events
- Over 20,000 non-volatile memories for tuner settings
- Four memory banks per antenna with over 2500 memories per bank
- Highly efficient switched-L network matching circuit
- Direct read-out of matching L/C values available after tuning
- 1.8 to 30 MHz continuous frequency coverage
- Adjustable target SWR from 1.0 to 2.0
- Adjustable SWR threshold from 0.5 to 1.5
- Adjustable amp bypass SWR from 1.5 to 3.0
- Lighted cross-needle SWR/wattmeter with high, low, and auto range options
- Multifunction backlit LCD display with contrast control
- Numeric readings for SWR, forward and reflected power
- Bar meters for SWR, forward and reflected power with peak hold and range options
- Audio SWR meter
- Built-in frequency counter for remembering frequency-specific matching values
- Built-in radio interface circuitry for compatible radios
- Two SO-239 coax fed antenna connectors
- Connector for random wire or single wire antennas
- Field upgradeable firmware

Specifications

- Impedance matching range : 12 to 1600 ohms
- SWR matching range : Up to 4:1 for < 50 ohms and up to 32:1 for > 50 ohms
- Minimum power for tuning : 5 watts
- Maximum power while tuning : 100 watts with foldback, 20 watts without foldback
- RF power limit : 1500 watts SSB/CW
- Frequency range : 1.8 to 30 MHz continuous coverage
- Frequency counter accuracy : ± 1 kHz across HF bands
- A/D conversion resolution : 10-bit
- Forward power display resolution : 0.1 for < 100 watts and 1 for ≥ 100 watts
- Reflected power display resolution : 0.1 for < 10 watts and 1 for ≥ 10 watts
- SWR display resolution : 0.1
- Power bar meters resolution : 60 segments
- SWR bar meter resolution : 31 segments
- Capacitance range : 0 to 3926 pF nominal (256 values) on input side
: 0 to 976 pF nominal (64 values) on output side
- Inductance range : 0 to 24.28 μ H nominal (256 values)
- Relay rating : 16 amp 1000 volts
- Relay electrical life : 100,000 operations
- Relay mechanical life : 10 million operations
- Memory endurance : 1 million erase/write cycles
- Memory data retention : > 200 years
- Power supply requirement : 12 - 15 volts DC
- Current consumption : 1.4 amps or less
- Dimensions (projections included) : 12 $\frac{3}{4}$ \times 4 \times 14 $\frac{3}{4}$ in; 325 \times 102 \times 375 mm (w \times h \times d)
- Weight : Approx. 7 lb 12 oz; 3.5 kg
- Display : 2-line \times 16-character backlight LCD
- TRANSMITTER connector : SO-239
- ANTENNA connectors : SO-239 \times 2
- WIRE connector : Ceramic binding post
- POWER connector : 2.1 \times 5.5 mm coaxial plug, center pin positive
- RADIO INTERFACE connector : 8-pin modular (RJ-45)
- RS-232 connector : D-sub 9-pin
- AMP ENABLE connectors : Phono (RCA) \times 2

† Specifications and design are subject to change without notice or obligation.

Transceiver Protection

Like all MFJ *IntelliTuners*[™], the MFJ-998 can provide automatic control interfacing with most popular transceivers through optional transceiver interface cables. When interfaced to your transceiver with the appropriate cable, the MFJ-998 automatically puts your transceiver into a low power CW tune mode when tuning is initiated. More details are provided in the “Radio Interface” section of this manual.

Note: *An optional transceiver interface cable is NOT necessary for normal operation. However, a transceiver interface cable simplifies operation by automatically keying your transceiver in a low power TUNE mode.*

Amplifier Protection

The MFJ-998 is unique in that it provides *Amplifier Bypass Control*[™] for hands-free protection of your amplifier during tuning and high SWR events. This capability is provided by passing the amplifier enable control line to your amplifier through the MFJ-998 **AMP ENABLE IN/OUT** connectors. A normally closed high-speed reed relay interrupts the amplifier enable signal when the MFJ-998 begins tuning, or when a user high-SWR pre-set is exceeded. A normally closed relay is used so that your amplifier system works properly when the MFJ-998 is turned off.

Note: *MFJ recommends that the amplifier enable control signal be **always** connected through the AMP ENABLE IN/OUT connectors on the MFJ-998.*

Note: *Some amplifiers will not un-key when the amp-disable line is interrupted if RF is present. This is done to ensure that there is no possibility of hot-switching the amplifier output should the driving transceiver have a premature amp-disable control signal. While the MFJ-998 will not tune if forward power exceeds 125 watts, it is best to not use the fully automatic tuning mode of the MFJ-998 when used with any amplifier with this feature. That is, MFJ-998 tuning should be manually started so you can manually take the amplifier off-line before beginning tuning.*

Note: *When a band data cable is used with Yaesu radios to interface with an amplifier, the amp-keying line may be included in this cable. If so, then this bypasses the MFJ-998 amp-disable feature. To correct this, disconnect the wire from Pin 2 (TX GND) on the Band Data connector cable going to the Yaesu radio and use the normal amp-key phono jack output from the radio for amp-keying. This amp-keying line can then be passed through the AMP ENABLE IN/OUT connectors on the MFJ-998.*

Fast Start

WARNING

- **Never operate the tuner with its cover removed. Contact with the components inside the tuner while transmitting will result in painful RF burns.**
- **Locate the tuner so that the rear terminals are *not accessible* during operation. The single wire connection may have high voltage while transmitting.**
- **Disconnect all antennas from the tuner during lightning storms.**
- **Always tune with low power (approximately 10-30 watts). Apply maximum power only after tuning up.**
- **Never exceed tuner specifications.**

Connect the MFJ-998 to the transceiver, the amplifier, and the antenna as shown in Figure 1 and per the following directions:

1. Connect the MFJ-998 to a 12-15 VDC voltage source capable of supplying at least 1.4 amps.
2. Connect your transceiver to the TRANSMITTER connector using a 50-ohm coaxial cable.
3. Connect your coax-fed antenna to the ANTENNA 1 connector using a 50-ohm coaxial cable, or connect your random wire to the WIRE binding post.
4. Connect your ground connection to the GROUND post.
5. Connect the AMPLIFIER ENABLE output from your transceiver to the AMP ENABLE IN on the MFJ-998, and connect the AMP ENABLE OUT on the MFJ-998 to the AMPLIFIER ENABLE INPUT on your amplifier.

Note: *If you use an amplifier keying interface between your transceiver and your amplifier, such as the Ameritron ARB-704, this amplifier keying interface may be placed either between the transceiver and MFJ-998, or between the MFJ-998 and amplifier.*

6. If available, connect an MFJ-5114 transceiver control cable between the MFJ-998 and your transceiver. Make sure to select your transceiver in the MFJ-998 Radio Interface setup menu.
7. Press the [POWER] button to turn on the MFJ-998 tuner.
8. Press the [ANT] button momentarily until a small "1" appears on line one of the display. This selects antenna 1 and is indicated with one beep.
9. Key your transceiver to output a carrier of 5-30 watts CW, FM or AM.

Note: *When a transceiver interface cable is used, initiating the TUNE cycle automatically keys your transceiver in the low power TUNE mode.*

10. Press and hold the [TUNE] button one second to start the automatic tuning process. When completed, check to ensure an SWR of 1.5 or less has been achieved before increasing RF power.

Note: *If you have a tuning solution on one band or antenna and you then change bands or antenna and attempt to transmit a tuning signal, the previous tuning solution may be sufficiently severe such that no power is detected by the MFJ-998 (the MFJ-998 will tell you to increase power). When this occurs, simply bypass the MFJ-998 and then initiate a tune.*

Note: During the automatic tuning process, the tuner will make some noise. These are the relays switching at a very high rate and this is normal. Do not be alarmed.

11. You are ready to transmit with full power.

Note: When the tuner power is OFF, the tuner is bypassed and RF from the transmitter goes directly to ANTENNA 1 with no matching. The tuner also powers up in the bypass mode. When the tuner power is ON, pressing [C-DN] and [L-DN] simultaneously or pressing [TUNE] quickly places the tuner in bypass mode if desired, which is indicated by one beep.

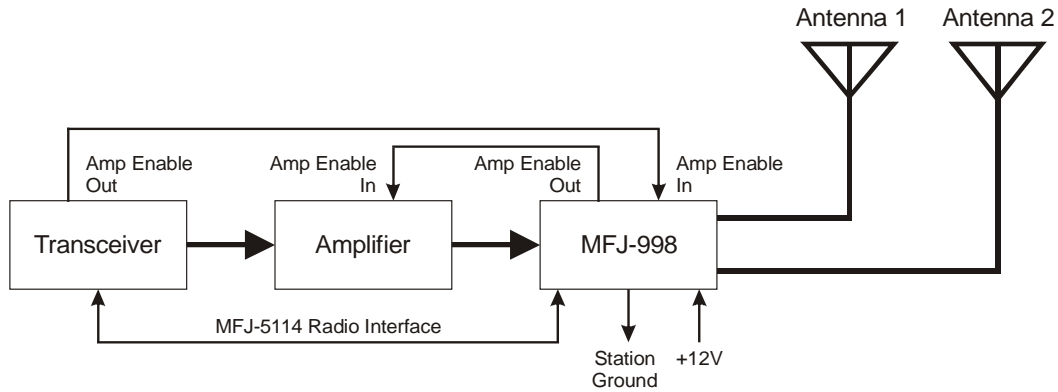

Figure 1. Typical Installation Block Diagram.

Front Panel

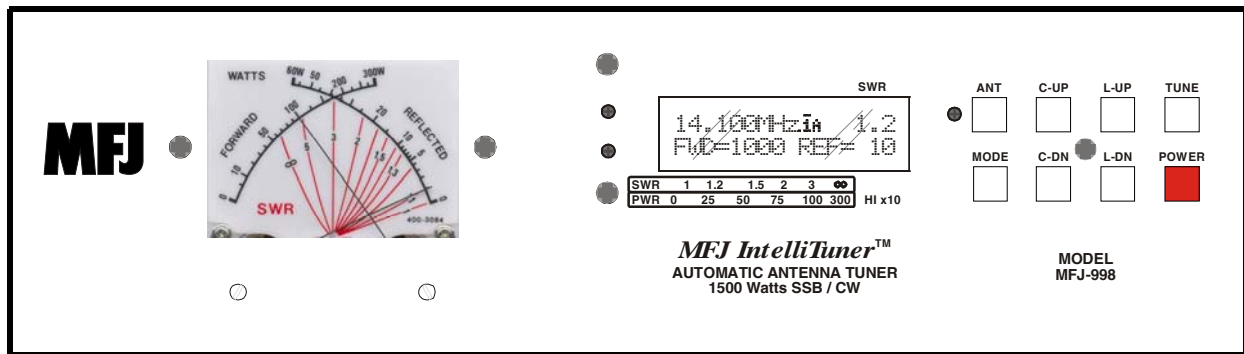

Figure 2. MFJ-998 Front Panel.

- **SWR/Wattmeter:** The cross-needle meter measures forward power, reflected power, and SWR. It operates whenever the MFJ-998 is powered on. Full-scale readings are 300 watts forward and 60 watts reflected power. The meter can be set to a high power range of 3000 watts forward and 600 watts reflected. The SWR is measured at the point where the two needles cross. See “SWR/Wattmeter” on page 14 for more detailed information.
- **Analog Meter Zero Scale Adjustment:** Two zero adjustment screws, located below the analog meter, calibrate the zero scales of the forward and reflected needles. The small hole on the right adjusts the forward needle and the small hole on the left adjusts the reflected needle. See “Analog Meter Calibration” section on page 30 for the calibration procedure.

- **Analog Meter Full Scale Adjustment:** Two trimpots, located to the left of the LCD display, calibrate the full scales of the forward and reflected needles. The small hole on the top adjusts the forward needle and the small hole on the bottom adjusts the reflected needle. See “Analog Meter Calibration” section on page 30 for the calibration procedure.
- **LCD Display:** A 2-line by 16-character alphanumeric display with backlight. It displays the tuner’s various menus and status. The display contrast can be adjusted by the LCD contrast control on the front panel. Below the display are the SWR and power bar meter scales. Refer to Figures 16 and 17 for descriptions of the various displayed information.
- **LCD Contrast Control:** A trimpot control that adjusts the contrast of the LCD display. Use a small flat blade screwdriver, insert into the small hole to the right of the display, and turn clockwise to increase contrast.
- **ANT Button:** Has two different functions based on the length of time you press and hold it before releasing. Press [ANT] quickly (less than one second) to toggle between Antenna 1 and Antenna 2. The Antenna indicator on the main display indicates the selected antenna. A single-wire antenna is, by default, Antenna 1.

Press and hold [ANT] for one second to cycle among the four memory banks of the current antenna. The selected bank is indicated by a series of short beeps, where one beep indicates bank A, two beeps indicate bank B, three beeps indicate bank C, four beeps indicate bank D, and five beeps indicate antenna memory is OFF. The Memory indicator on the main display also indicates the selected bank.

Pressing the [ANT] button switches the antenna or bank *only* when there is no RF power. Also, the tuner setting for the selected antenna or bank, if available, is instantly restored from memory when enabled.

- **MODE Button:** Time-sensitive and used to navigate through the various main menus and to enter or exit the setup menus.
- **C-UP and C-DN Buttons:** Used to manually increase or decrease the capacitance of the L-network matching circuit. The capacitance ranges are 0 to 3926 pF (picofarads) on the input side and 0 to 976 pF on the output side. The upper limit of capacitance, dependent on frequency, is used to limit the maximum voltage and current across the tuner’s components. This limit can be removed in the LC Limit setup menu, but is not recommended.

Note: Pressing [C-UP] and [C-DN] simultaneously toggles the capacitor between the input and output sides of the L-network. One beep when the capacitor is on the antenna side. Two beeps when the capacitor is on the transmitter side.

- **L-UP and L-DN Buttons:** Used to manually increase or decrease the inductance of the L-network matching circuit. The inductance range is 0 to 24.28 μ H (microhenries). The upper limit of inductance, dependent on frequency, is used to limit the maximum voltage and current across the tuner’s components. This limit can be removed in the LC Limit setup menu, but is not recommended.

Note: Pressing [C-DN] and [L-DN] simultaneously places the tuner in bypass mode. One beep sounds to indicate bypass mode, and RF from the transmitter goes directly to the antenna with no matching.

- **TUNE Button:** Has three different functions based on the length of time you press and hold it before releasing. Press [TUNE] quickly (less than 0.5 second) to bypass the tuner. One beep indicates bypass mode, where RF from the transmitter goes directly to the antenna with no matching. A second quick press toggles the tuner back to its last L/C setting, and the tuner responds with two beeps.

Note: Always connect the amplifier enable line from your transceiver output through the MFJ-998 to the amplifier. This always ensures that the amplifier will be taken off-line prior to any tuning events.

Press [TUNE] for 0.5 to 2 seconds to start the automatic tuning process. Tuning starts when [TUNE] is released after the 0.5-2 second hold-time. The transmitter must be keyed first with at least five watts of power. When the SWR is already below the target SWR, pressing [TUNE] will fine-tune the match for a lower SWR if possible.

Note: You can reverse the two functions above by pressing and holding the [TUNE] button for approximately 10 seconds. I.e., when the [TUNE] button is pressed and held for 10 seconds. You will hear two beeps. Now pressing [TUNE] momentarily starts the tuning process, and pressing and holding the [TUNE] button for 0.5-2 seconds puts the tuner into the bypass mode.

“StickyTune™” allows for one-handed tuning operation. Normal tuning requires keying the transmitter with one hand and using the other hand to push the [TUNE] button to start the tuning process unless a transceiver interface cable is installed. When StickyTune™ is enabled, a bar appears on top of the Auto/Semi indicator and the tuning process starts automatically when the transmitter is keyed with at least five watts of power regardless of the SWR. This works in both automatic and semi-automatic modes. To toggle the StickyTune™ mode on and off, press and hold the [TUNE] button for two seconds. One beep indicates on and two beeps indicate off. Default is off.

Automatic/Semi-Automatic Tuning Mode

Pressing [TUNE] and [ANT] simultaneously toggles between automatic and semi-automatic tuning mode. In automatic mode, the tuning routine is automatically started when at least five watts of power is applied and the SWR is a preset amount above the preset target SWR. In semi-automatic mode, the tuning routine starts only when the [TUNE] button is pressed for 0.5 to 2 seconds. The Auto/Semi indicator on the main display indicates the selected mode. Refer to Figures 16 and 17 for the on-screen Auto/Semi indicator.

Note: During the tuning process, the tuner will make some noise. These are the relays switching at a very high rate and this is normal. Do not be alarmed.

- **POWER Button:** Used to turn the power on and off. When the power is off, the tuner is bypassed (straight through from TRANSMITTER to ANTENNA 1 and WIRE) and the amplifier bypass control line is uninterrupted by the MFJ-998. When power is turned on, the tuner powers-up bypassed, but will revert to the last stored matching values or begin tuning on application of RF power when the [TUNE] button is pressed. Also, the target SWR appears on the main screen.

WARNING: Do not turn the power on and off rapidly, otherwise the tuner setting memory can be corrupted and the unit will have to be reset to factory defaults.

Note: When the tuner power is OFF, the tuner is bypassed and RF from the transmitter goes directly to ANTENNA 1 with no matching.

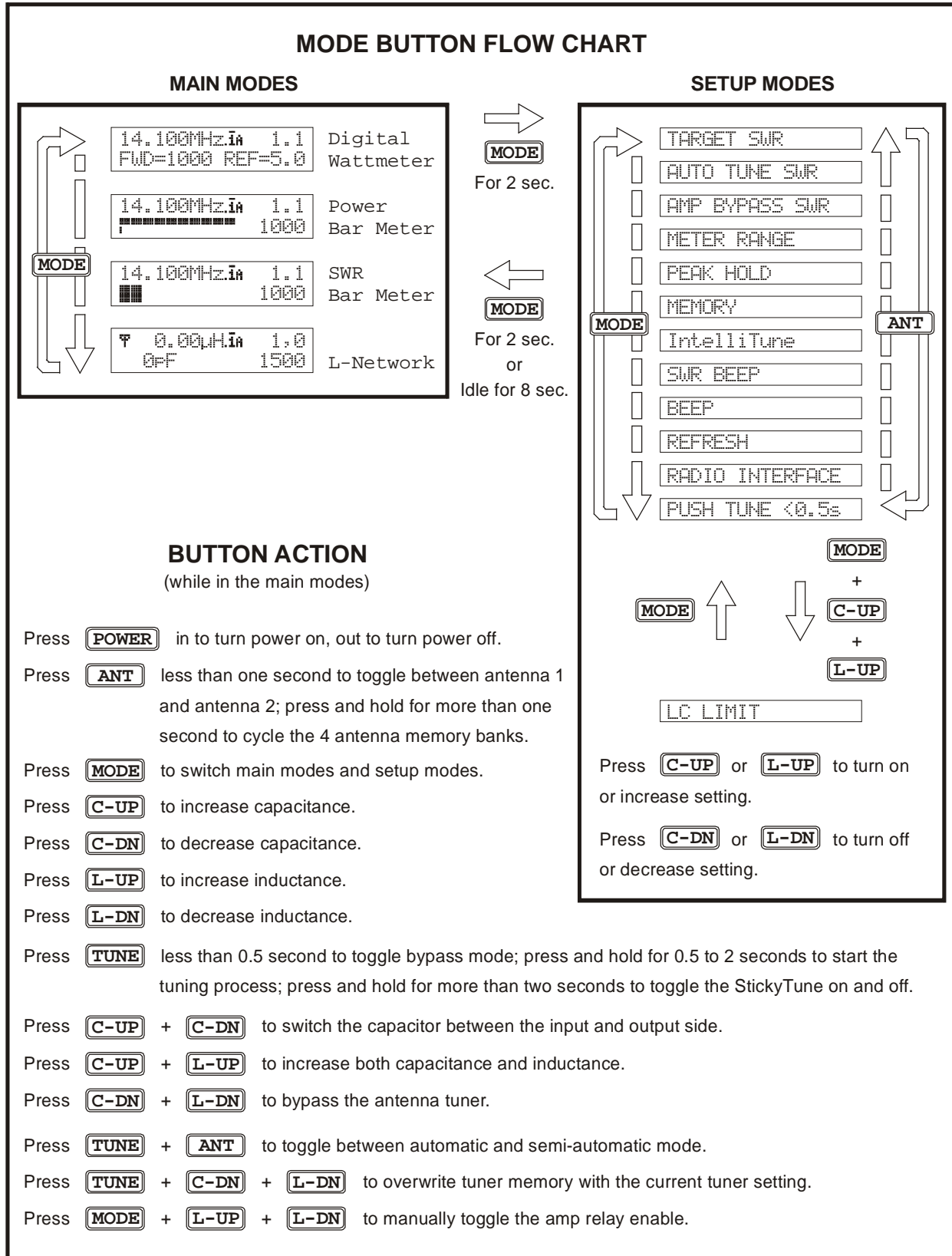

Figure 3. Mode Button Flow Chart and Button Action.

Back Panel

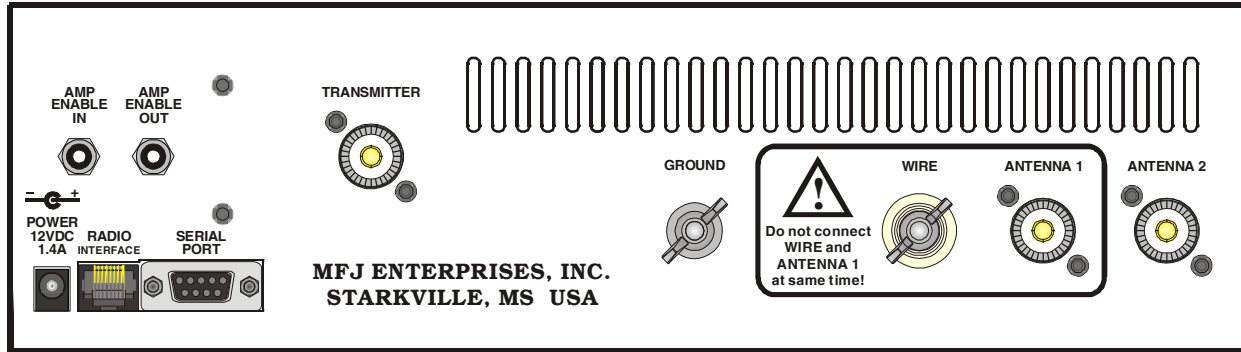

Figure 4. MFJ-998 Back Panel.

- **Amp Enable In:** RCA phono connector for connecting to the radio’s amplifier control output.
- **Amp Enable Out:** RCA phono connector for connecting to the amplifier’s relay control input.
- **Power:** This jack accepts a standard 2.1 × 5.5 mm coaxial plug with positive center and negative sleeve. The tuner requires 12-15 volts DC at up to 1.4 amps. The use of a regulated supply is not mandatory but is recommended for best performance. An optional 12 volt DC 1.5 amp power supply, the MFJ-1316, is available from MFJ Enterprises, Inc.

WARNING: Do not apply voltages greater than 18 volts to this unit, or permanent damage may result.

Note: When the tuner power is OFF, the tuner is bypassed and RF from the transmitter goes directly to ANTENNA 1 with no matching. When turned on, the tuner powers up in bypass mode.

- **Radio Interface:** An 8-pin modular (RJ-45) connector for connecting to the tuner interface connector of compatible radios. While most radios provide +13.8 VDC power though their tuner interface connector, a separate power supply is necessary to power the MFJ-998 due to its 1.4 amp power requirement. The MFJ-998 should be powered on first (for certain radios, TURN ON RADIO will display) and then the radio powered on so the radio knows an external tuner is attached. The radio will disable its internal tuner, if it has one, and use the external tuner.

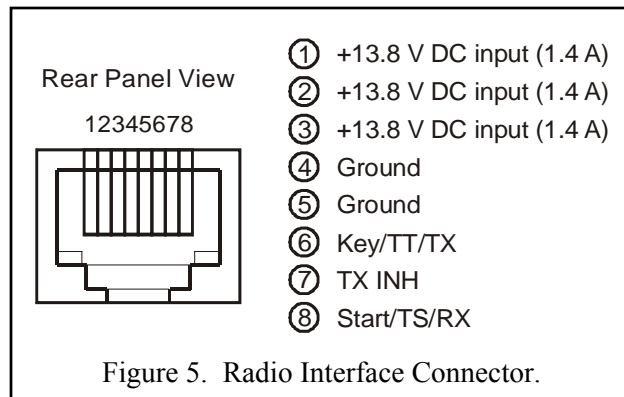

Figure 5. Radio Interface Connector.

The Radio Interface works with radios that are compatible with Alinco EDX-2, Icom AH-3 and AH-4, Kenwood AT-300, and Yaesu FC-30, FH-1 and FH-2. When connected to a compatible radio, simply press the [TUNER] or [AT] button on the radio; for FH-1 or FH-2 compatible Yaesu, press the [TUNE] button *on the tuner* to start the automatic tuning process. The radio will automatically switch

to CW mode, transmit a low power (typically 10-30 watt) carrier, and start the tuning process. Once the automatic tuning is completed, the radio will return to its previous mode and power setting.

Jumper JP1

There is a jumper JP1 inside the MFJ-998 that must be configured properly when interfacing to the various radios. Normally this jumper is installed and is the factory default. **Remove this jumper when interfacing to an Icom IC-7000.** Make sure this jumper is installed when interfacing to Kenwood radios and FC-30 compatible Yaesu radios using the MFJ-5114K and MFJ-5114Y interface cables, respectively. For the other radios, the position of jumper JP1 is irrelevant.

Note: The MFJ-998 must be powered from a separate DC source. Power from the accessory or tuner connector is not passed to the MFJ-998 via the transceiver interface cable.

Note: If the wrong interface is selected and the *TURN ON RADIO* message does not go away, disable the interface by pressing and holding both [TUNE] and [MODE] buttons while turning on the power. The tuner will respond with two beeps. Then select the correct interface using the MFJ-998 Radio Interface setup mode.

The MFJ-5114A interface cable provides control signals between an Alinco radio and the MFJ automatic tuner. Supported Alinco radios are DX-70, DX-77, DX-701, DX-801, and any Alinco radio that supports the Alinco EDX-2 tuner. Press the radio's [TUNE] button to start the tuning process; for DX-70 press [FUNC] then [TUNE]. Refer to "Alinco Radio Interface" on page 33 for connections and operation.



- ① Pin 1 (Ground) connects to pins 4 and 5 of Radio Interface Plug.
- ② Pin 2 (+13.8V) connects to pins 2 and 3 of Radio Interface Plug.
- ③ Pin 3 (Key) connects to pin 6 of Radio Interface Plug.
- ④ Pin 4 is not connected.
- ⑤ Pin 5 (Start) connects to pin 8 of Radio Interface Plug.

Figure 6. Alinco Interface Cable.

The MFJ-5114I interface cable provides control signals between an Icom radio and the MFJ automatic tuner. Supported Icom radios are IC-706, IC-707, IC-718, IC-725, IC-728, IC-736, IC-738, IC-746, IC-756, IC-7000, and any Icom radio that supports the Icom AH-3 or AH-4 tuner. Push and hold the radio's [TUNER] button for two seconds to start the tuning process. Push [TUNER] quickly to bypass the tuner. **Make sure jumper JP1 inside the MFJ-998 is removed for IC-7000.** Refer to "Icom Radio Interface" on page 34 for connections and operation.

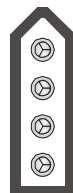

- ① Pin 1 (Key) connects to pin 6 of Radio Interface Plug.
- ② Pin 2 (Start) connects to pin 8 of Radio Interface Plug.
- ③ Pin 3 (+13.8V) connects to pins 2 and 3 of Radio Interface Plug.
- ④ Pin 4 (Ground) connects to pins 4 and 5 of Radio Interface Plug.

Figure 7. Icom Interface Cable.

The MFJ-5114K interface provides control signals between a Kenwood radio and the MFJ automatic tuner. Supported Kenwood radios are TS-50S, TS-450S, TS-480HX, TS-570S, TS-690S, TS-850S, TS-870S, TS-2000, and any Kenwood radio that supports the Kenwood AT-300 tuner. Push and hold the radio's [AT TUNE] button for one second to start the tuning process. Push the [AT TUNE] quickly to bypass the tuner or to cancel tuning in progress. Make sure jumper JP1 is installed. Refer to "Kenwood Radio Interface" on page 35 for connections and operation.

Note: The TS-480HX will automatically reduce its TX power to 100 watts maximum (25 watts AM) when the radio interface is used.

Note: For the TS-2000, use the ANT 1 and AT connectors on the radio to connect an external antenna tuner. If the external tuner is connected to the ANT 2 connector on the radio, the external tuner will not function with the radio interface.

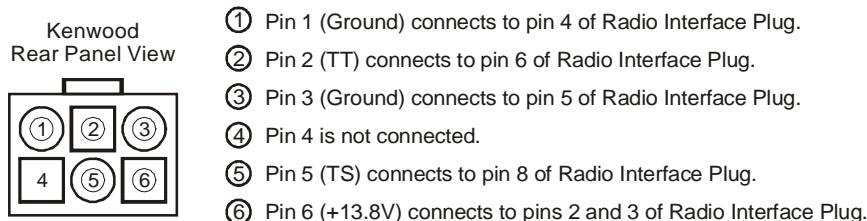

Figure 8. Kenwood Interface Cable.

The MFJ-5114Y interface provides control signals between a Yaesu radio and the MFJ automatic tuner. Supported Yaesu radios are FT-100, FT-450, FT-857, FT-897, FT-950, and any Yaesu radio that supports the Yaesu FC-30 tuner. Push and hold the radio's (TUN) or (TUNE) key to start the tuning process. Make sure jumper JP1 is installed. Refer to "Yaesu Radio Interface/MFJ-5114Y" on pages 36 to 39 for connections and operation.

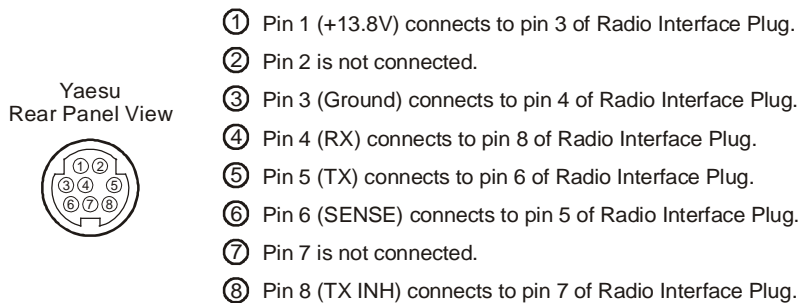

Figure 9. Yaesu Interface Cable (FT-100/-450/-857/-897/-950).

The MFJ-5114Y3 interface provides control signals between a Yaesu radio and the MFJ automatic tuner. Supported Yaesu radios are FT-1000MP, FT-1000MP MKV, FT-1000MP MKV Field, FT-2000, FTDX-9000, and any Yaesu radio compatible with the Yaesu FH-1 or FH-2 Remote Control. This cable plugs into the REMOTE jack on the rear panel of the Yaesu radios, and keys the Yaesu radios in the CW tune mode whenever the MFJ-998's [TUNE] button is pushed. MFJ recommends that the Yaesu CW tune setting be set to 10 watts (Yaesu MP menu selection 4-3) during the tune process when an amplifier is not used. For best accuracy when an amplifier is used, MFJ recommends that the Yaesu CW tune setting be set to 50 watts for 100-watt transceivers and 75 watts for 200-watt MKV transceivers during the tune process. If a FH-1 or FH-2 keypad is also used, both

the FH-1/FH-2 and the radio control cable may be plugged in parallel using a 3.5-mm headphone splitter (mono or stereo is fine). Refer to “Yaesu Radio Interface/MFJ-5114Y3” on page 40 for connections and operation.

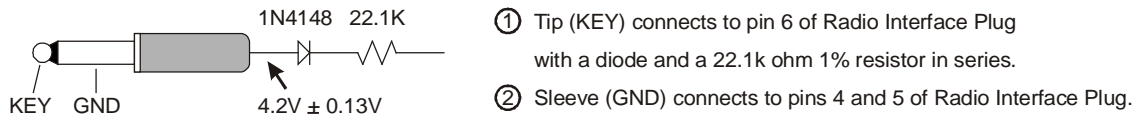

Figure 10. Yaesu Interface Cable (MP/2000/9000 series).

While the MFJ-5114Y3 works with the FT-2000, the FT-2000 also has a TX REQ input that can be used. If you prefer to use the TX REQ input, the MFJ-5114Y4 interface provides control signals between the Yaesu FT-2000 and FT-2000D radios and the MFJ automatic tuner. This cable plugs into the TX REQ RCA jack on the rear panel of these Yaesu radios, and keys the Yaesu radios in the CW tune mode whenever the MFJ-998’s [TUNE] button is pushed. MFJ recommends that the Yaesu tune power setting be set to 20 watts (Yaesu menu 145 tGEN TUN PWR) during the tune process. Refer to “Yaesu Radio Interface/MFJ-5114Y4” on page 42 for connections and operation.

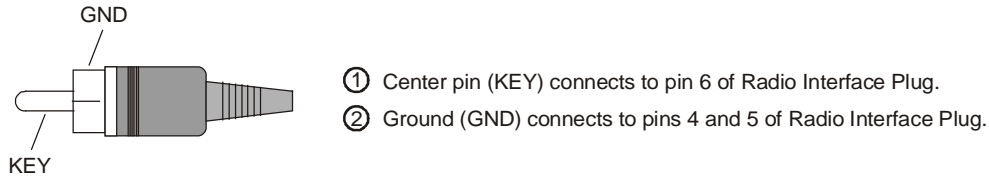

Figure 11. Yaesu Interface Cable (FT-2000 series).

- **Serial Port:** DB-9 female connector for connecting to the computer’s RS-232 serial port to update firmware. Check <http://www.mfjenterprises.com/support.php> for the latest version of the firmware.
- **Transmitter:** SO-239 connector for coax cable from transceiver or amplifier.
- **Ground:** Wing-nut terminal for RF ground wire connection.
- **Wire:** Binding post for connecting single wire antenna. The WIRE binding post is internally connected to the ANTENNA 1 connector.

Note: When using the WIRE binding post, there should be no coax cable connected to the ANTENNA 1 connector.

- **Antenna 1:** SO-239 connector for coax cable from antenna. The ANTENNA 1 connector is internally connected to the WIRE binding post.

Note: When using the ANTENNA 1 connector, there should be no wire attached to the WIRE binding post.

- **Antenna 2:** SO-239 connector for coax cable from antenna.

Installation

WARNING

- **Never operate the tuner with its cover removed. Contact with the components inside the tuner while transmitting will result in painful RF burns.**
- **Locate the tuner so that the rear terminals are *not accessible* during operation. The single wire connection may have high voltage while transmitting.**
- **Disconnect all antennas from the tuner during lightning storms.**
- **Always tune with low power (approximately 10-30 watts), and any in-line amplifier must be bypassed. Apply maximum power only after tuning up.**
- **Never exceed tuner specifications.**

1. Place the tuner in a convenient location at the operating position. When using a random wire antenna the feed through insulator may have high RF voltages. These voltages can cause serious RF burns if the terminal is touched when transmitting. **Be sure to locate the tuner so this terminal cannot accidentally be contacted during operation.**
 2. Connect the tuner to the transceiver or amplifier with 50-ohm coaxial cables capable of handling the RF power levels expected. See Figure 1 on page 6.
 3. Connect the antenna(s) to the tuner as follows:
 - Coaxial feedlines (RG-8/U or better) to the SO-239 connectors labeled ANTENNA 1 and/or ANTENNA 2.
 - Random wire to the WIRE binding post on the back of the tuner. Note the back panel warning: **Do not connect WIRE and ANTENNA 1 at same time!** When a single wire antenna is connected it “becomes” ANTENNA 1.
- Note:** Route all random wire antennas safely to prevent a RF burn hazard.
- For balanced feedlines, connect an MFJ-912 1.5 kW 4:1 balun to the appropriate antenna connector output of the MFJ-998.
 4. A GROUND post is provided for an RF ground connection. See “Grounding Hints” on page 25.
 5. Connect a 12 to 15 VDC power source capable of 1.4 amps to the input jack labeled POWER.

SWR/Wattmeter

The backlit cross-needle analog meter measures forward power, reflected power, and SWR, and operates whenever the tuner is powered on. Forward power up to 300 watts is displayed on the left-hand FORWARD meter scale. Reflected power up to 60 watts is read on the right-hand REFLECTED meter scale. For high-power tuning, meter ranges of 3000 watts forward and 600 watts reflected are available. Multiply the readings on these scales by ten when in the high power meter range.

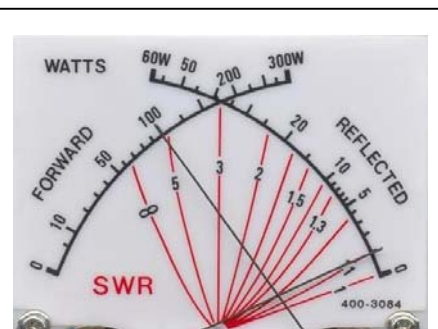

Figure 12. SWR/Wattmeter.

The meter can be set to low, high, or auto range (default). Auto range automatically sets the meter scales according to the input RF power to the tuner. Forward power greater than 300 watts or reflected power

greater than 60 watts automatically sets the meter to the high power range. Forward power less than 250 watts and reflected power less than 40 watts automatically set the meter to the low power range. When auto range is enabled, a two-dot vertical segment appears in the lower right corner of the Auto Range indicator on the main LCD screen. Refer to Figures 16 and 17 for the on-screen Auto Range indicator.

SWR is calculated from the forward and reflected power measurements as shown by the equation at the right. The SWR is read from the 11 red SWR curves ranging from 1.0 to infinity by observing the point where the forward and reflected power needles cross on the red curved scales across the center of the meter. No cumbersome or time-consuming SWR sensitivity adjustments are required with this meter. Figure 12 shows an SWR of approx. 1.2.

$$SWR = \frac{1 + \sqrt{\frac{\text{reflected power}}{\text{forward power}}}}{1 - \sqrt{\frac{\text{reflected power}}{\text{forward power}}}}$$

The MFJ-998 also includes an SWR bar meter and an audio SWR indicator. It also has bar meters for forward and reflected power.

The Menus

Main Mode Menus

The main mode menus show various tuner settings and status. There are four main mode menus arranged in a “wrap-around” structure. When powered on, tuner operation starts with the main menu that was last used. Within each main menu, press the [MODE] button briefly to view the next main menu. Press and hold the [MODE] button for two seconds to enter the setup mode (see below). Various tuner indicators are shown on all four main menus: Antenna 1/2, IntelliTune™, Radio Interface, Memory, LC Limit, Auto Range, Auto/Semi, and StickyTune™. Refer to Figures 16 and 17 for details on the displayed information.

Note: *In sideband mode, the frequency readout on the tuner display jumps around to different frequencies while transmitting and stops on another frequency when un-keyed. This is normal and is a characteristic of sideband mode, because sideband signals jump around in frequency and power.*

Note: *The decimal point in the SWR reading is replaced with a comma to indicate bypass mode.*

Digital Wattmeter Menu

Shows the frequency, SWR, and forward and reflected power in watts.

Power Bar Meter Menu

Shows the frequency, SWR, forward power, and bar meters for forward and reflected power. The top bar meter is the forward power and the bottom bar meter is the reflected power. The numeric reading of forward power appears at the end of the bar meters. A power scale is printed just below the display on the front panel. Each power bar meter consists of 60 bar segments. When in the high power range, multiply the readings on the printed power scale by ten, and each vertical bar segment consists of three dots. Below 1000 watts, each bar segment represents 20 watts; above 1000 watts, each bar segment represents 200 watts. The forward bar meter has a “peak hold” feature. The peak meter hold function (default) freezes the highest displayed bar segment of the forward power for about one second, so that you can more easily read the meter. This function can be turned ON and OFF in the Peak Hold setup mode.

For low-power tuning, meter range of 300 watts is available. When in the low power range, each vertical bar segment consists of two dots. Below 100 watts, each bar segment represents two watts; above 100 watts, each bar segment represents 20 watts. Refer to the “SWR/Wattmeter” section on page 14 for more details on power range.

The power meter default condition is auto range. Auto range automatically sets the meter scale according to the input RF power to the tuner. Forward power greater than 300 watts or reflected power greater than 60 watts automatically sets the meter to the high power range. Forward power less than 250 watts and reflected power less than 40 watts automatically set the meter to the low power range. When auto range is on, a two-dot vertical segment appears on the on-screen tuner indicator. Refer to Figures 16 and 17 for the on-screen Auto Range indicator.

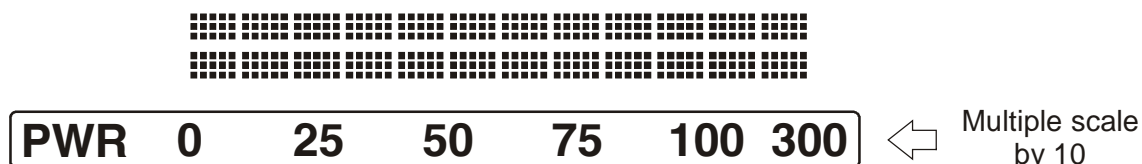

Figure 13. Power Bar Meter (High Range).

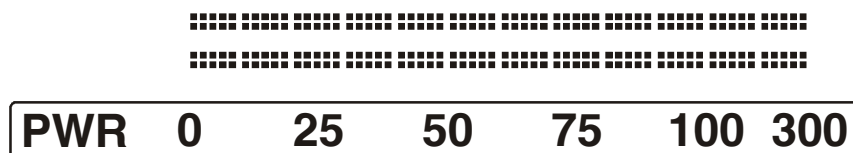

Figure 14. Power Bar Meter (Low Range).

SWR Bar Meter Menu

Shows the frequency, SWR, forward power, and SWR bar meter. A SWR scale is printed just below the display on the front panel. The 12-block (31-segment) SWR bar meter indicates SWR of 1.0, 1.1, 1.2, 1.3, 1.4, 1.5, 1.6-1.7, 1.8-2.0, 2.1-2.5, 2.6-3.0, 3.1-5.0, 5.1 to infinity. The numeric reading of forward power appears at the end of the bar meter. There is also an audio SWR indicator (see “SWR Beep Menu” section on page 21).

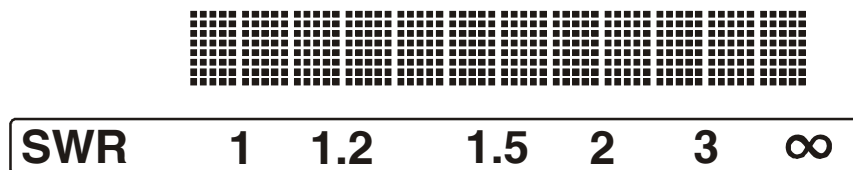

Figure 15. SWR Bar Meter.

L-Network Menu

Shows the configuration of the L-network matching circuit, SWR, and forward power. The antenna symbol, on the upper left corner, indicates the antenna side of the L-network. The capacitance value is displayed to the left when it is on the antenna side and to the right when it is on the transmitter side. Inductance value is shown in microhenries (µH) and capacitance value in picofarads (pF). The numeric reading of forward power appears at the lower right corner of the display. See “Manual Tuning” on page 22.

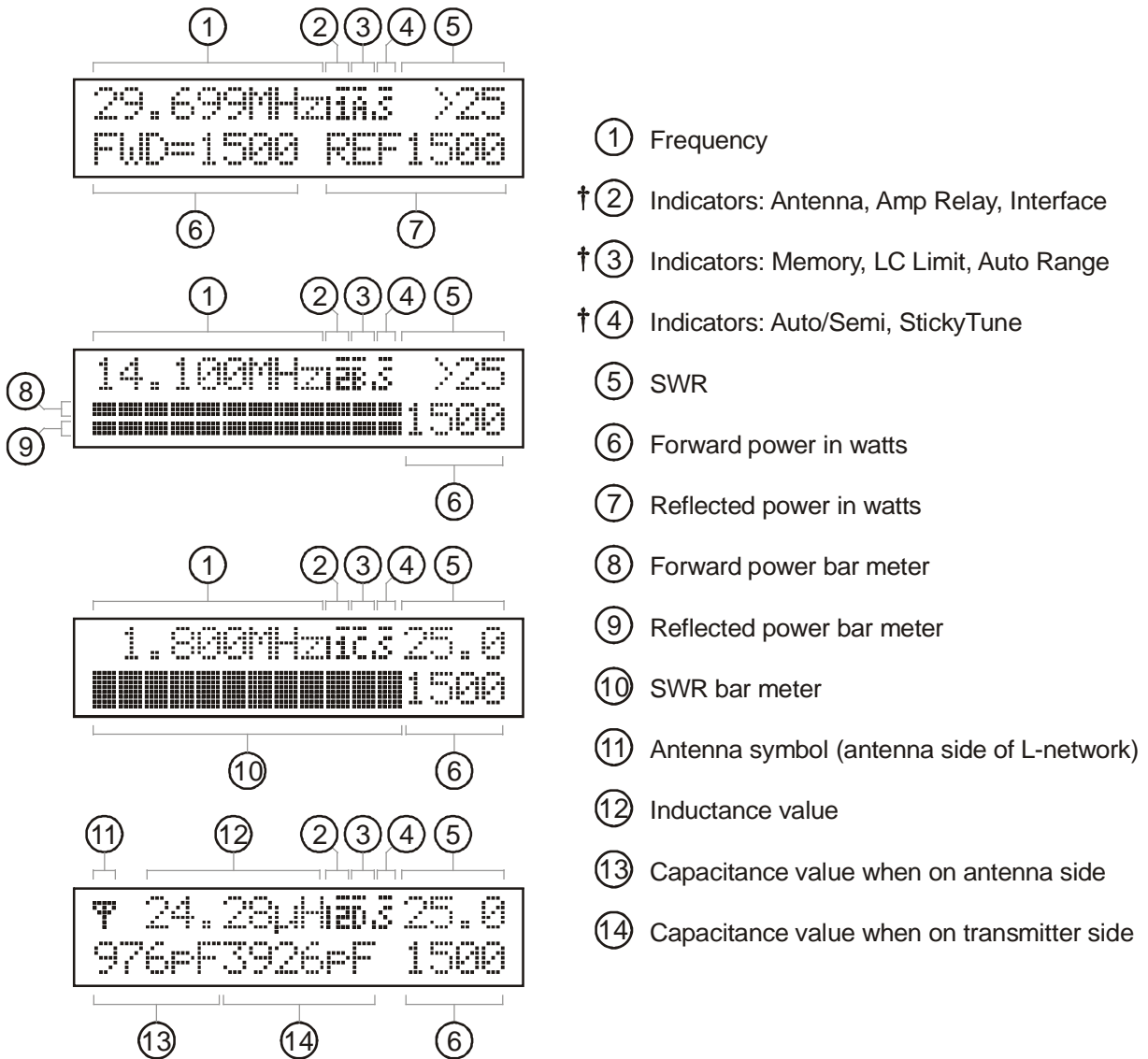

Figure 16. Main Mode Menus Display.

Tuner Indicators

Various tuner indicators are shown on the main menus to indicate tuner status. Refer to Figures 16 and 17 for locations of these indicators. The number enclosed within () is the item number of Figure 17.

- **Antenna:** A small “1” appears to indicate antenna 1 is selected (15); a small “2” appears to indicate antenna 2 is selected (16).
- **Radio Interface:** One dot appears on the left side of the Antenna indicator to indicate the selected radio interface (17-21).
- **Amp Relay Enable:** When Amp Relay Enable is OFF, a bar appears on top of the Antenna indicator (22).

- **Memory:** A small “A”, “B”, “C” or “D” appears to indicator the selected memory bank when Memory is ON (23-26); nothing appears when Memory is OFF.
- **LC Limit:** When LC Limit is OFF, a bar appears on top of the Memory indicator (27).
- **Auto Range:** When Auto Range is ON, a two-dot vertical bar segment appears on the lower left corner of the Memory indicator (28).
- **Auto/Semi:** A small “S” appears to indicate semi-automatic mode (29); nothing appears to indicate automatic mode.
- **StickyTune:** When *StickyTune*TM is ON, a bar appears on top of the Auto/Semi indicator (30).

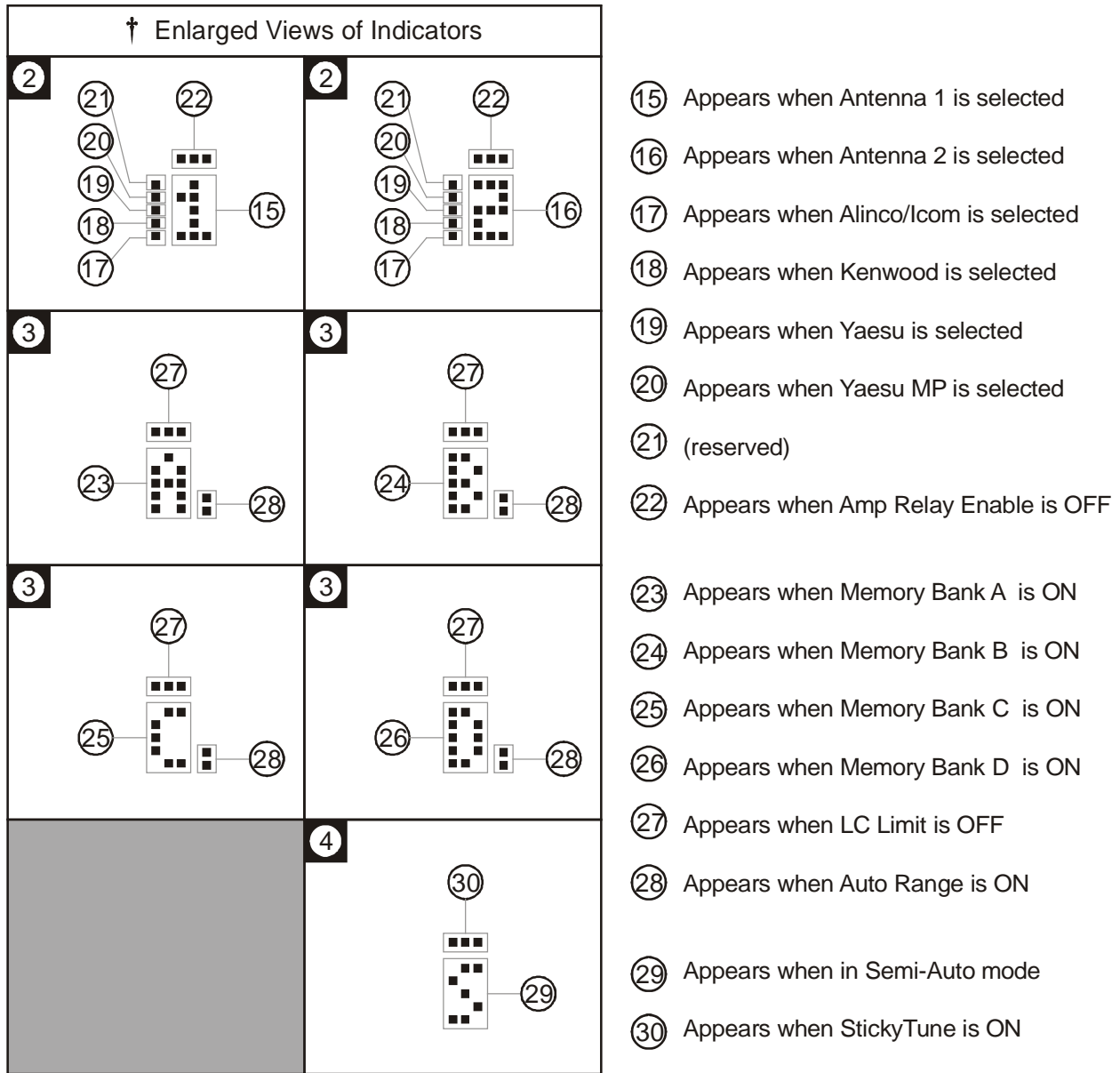

Figure 17. Tuner Indicators.

Setup Mode Menus

The setup mode menus allow you to customize how the MFJ-998 tuner operates. There are 13 setup mode menus arranged in a “wrap-around” structure. To access these setup menus, press and hold the [MODE] button for two seconds. The setup menu that will display is the one that was last used. When finished, press the [MODE] button for two seconds to go back to the main mode for normal operation.

The tuner goes into protective bypass mode in the setup mode and restores the matching network after exiting the setup mode. If no button is pressed for more than eight seconds, the tuner automatically exits the setup mode, restores the matching network, and returns to the main mode.

To access the LC Limit setup menu from any setup menu, press and hold the [MODE] button and within two seconds press both [C-UP] and [L-UP] buttons. This difficulty is built-in so the LC Limit is not accidentally disabled. Notice the LC Limit is not saved into non-volatile memory and will revert back to default ON when power is turned off. In addition, the following setup modes are stored separately for antennas 1 and 2: Target SWR, Auto Tune SWR, Amp Bypass SWR, Meter Range, Peak Hold, Memory, and *IntelliTune*[™].

Within each setup menu:

- Press the [MODE] button briefly to cycle forward through the setup menus. Press and hold the [MODE] button for two seconds to exit the setup mode and go back to the main mode.
- Press the [ANT] button to cycle backward through the setup menus.
- Press the [C-UP] or [L-UP] button to increase or turn on the setting for the current setup menu.
- Press the [C-DN] or [L-DN] button to decrease or turn off the setting for the current setup menu.

Target SWR Menu

Allows you to set the target SWR from 1.0 to 2.0. The tuning process will stop when a match with an SWR less than or equal to the target SWR is found. Setting the target SWR lower than 1.5 may result in longer tuning times. The target SWR is shown on the initial display when the tuner is powered on. Default is 1.5.

Auto Tune SWR Menu

Allows you to set the SWR threshold in the range 0.5 to 1.5. In the automatic mode, the tuning process will automatically start when the SWR is above the target SWR by this amount of SWR threshold. For example, for target SWR of 1.5 and auto tune SWR of 0.5, the tuning process will start whenever the SWR rises above 2.0 (1.5 + 0.5) and there is at least five watts of RF power applied. The AMP BYPASS feature of the MFJ-998 **MUST** be used when implementing Auto-Tune to prevent tuning under high power conditions. Default is 0.5.

Amp Bypass SWR Menu

Allows you to set the amplifier bypass SWR from 1.5 to 3.0. The amplifier connected to the Amp Enable connection will be bypassed when the SWR is above the amp bypass SWR. Default is 2.0.

Note: Pressing [MODE], [L-UP] and [L-DN] simultaneously toggles the Amplifier Bypass Control[™] feature ON and OFF; and disables the StickyTune[™] mode, if enabled. Refer to Figures 16 and 17 for the on-screen Amp Relay Enable indicator. If this feature is turned OFF (not recommended), it will be re-set to ON whenever power is cycled.

WARNING: Amplifier Bypass Control™ is a safety precaution; the tuner and amplifier are in danger of being damaged if this function is turned off.

Meter Range Menu

Allows you to select the meter scale range. In the 300 watts (low) range, the forward full scale is 300 watts and the reflected full scale is 60 watts. In the 3000 watts (high) range, the forward full scale is 3000 watts and the reflected full scale is 600 watts (multiple the meter reading by 10). Auto range automatically sets the meter scales according to the input RF power to the tuner. Forward power greater than 300 watts or reflected power greater than 60 watts automatically sets the meter to the high power range. Forward power less than 250 watts and reflected power less than 40 watts automatically set the meter to the low power range. Refer to Figures 16 and 17 for the on-screen Meter Range indicators. Default is AUTO Range.

Peak Hold Menu

When the peak hold function is ON, the highest activated segment of the forward bar meter remains visible for about one second, so that you can more easily read it. When OFF, the meter functions normally. Default is ON.

Memory Menu

Turns the antenna memory on and off. The “memory resolution” is the width of frequency spectrum that the tuner recognizes as being the same as a tuned frequency already in memory. The memory resolution is approximately 0.1 percent of the lower frequency of each amateur band. For example, the memory resolution on the 40-meter band (7000 to 7300 kHz) is 7 kHz; if the tuner has memorized a setting for 7050 kHz, it will automatically call up this setting for any frequency from 7047 to 7053 kHz. Memory resolution is smaller at lower frequency to accommodate the higher antenna Q and larger at higher frequency where the antenna Q is lower. The memory resolutions for the HF amateur bands 160 through 10 meters are:

Meter	Frequency Range (kHz)	Memory Resolution (kHz)
160	1800 – 2000	2
75/80	3500 – 4000	4
60	5330.5, 5346.5, 5366.5, 5371.5 and 5403.5	5 memory locations
40	7000 – 7300	7
30	10100 – 10150	10
20	14000 – 14350	14
17	18068 – 18168	18
15	21000 – 21450	21
12	24890 – 24990	25
10	28000 – 29700	28

Table 1. Memory Resolution.

The memory resolution for non-amateur frequency bands between 160 and 10 meters is approximately 0.2 percent of the lower frequency of each band. There are over 2500 memory locations for each memory bank, and each antenna has four memory banks (A-D). Tuner settings are stored in memory separately for Antenna 1 and Antenna 2 (settings for single-wire antenna are stored as Antenna 1). This provides memory for up to eight different antennas. Refer to Figures 16 and 17 for the on-screen Memory indicator. Defaults are memory banks 1A and 2A ON.

To clear an antenna memory bank, select the antenna memory bank with the [ANT] button and turn off the power to the tuner. Then press and hold both [TUNE] and [C-UP] buttons while turning on the power. A `DELETE BANK` message will appear.

To clear the memory for an antenna (all four banks), select the antenna with the [ANT] button and turn off the power to the tuner. Then press and hold both [TUNE] and [ANT] buttons while turning on the power. A `DELETE ANTENNA` message will appear.

“Total Reset” erases both antenna memories and returns all tuner settings to their factory default states. To achieve this, turn power off, press and hold [TUNE], [C-UP] and [L-UP] buttons while turning on the power. A `TOTAL RESET` message will appear.

Note: Pressing [TUNE], [C-DN] and [L-DN] buttons simultaneously overwrites the tuner memory with the current tuner setting; settings with SWR greater than 3.0 will not be stored.

IntelliTune Menu

Turns the *IntelliTune*TM tuning algorithm on and off. When the tuner cannot find an appropriate setting in its memory, it begins its calculation function. It measures the complex impedance of the antenna (load) at the transmitting frequency, and then it calculates the L/C components needed for a match. Then it fine-tunes the component values. If for any reason the tuner cannot calculate the load impedance, it proceeds to yet another method of calculation. If you wish, this function can be turned off. Default is ON.

SWR Beep Menu

Turns the audio SWR meter on and off. The audio meter is a series of beeps where one beep indicates SWR of 1.5 or less, two beeps indicate SWR of 1.6 to 2.0, three beeps indicate SWR of 2.1 to 2.5, and four beeps indicate SWR of 2.6 to 3.0. For SWR above 3.0, “SWR” (di-di-dit di-dah-dah di-dah-dit) will be sent on CW. This functions independent of the acknowledgement beep setting. Default is OFF.

Beep Menu

Acknowledgement beep sounds each time a parameter is changed to acknowledge it. This also controls the CW notification of “QRO”, “QRP” and “QRT”. This function can be turned OFF for silent operation, and this is independent of the SWR beep setting. Default is ON.

Refresh Menu

When the refresh function is ON, the display is updated while tuning is in progress. Default is OFF.

Note: Refresh slows tuning progress as it takes time to update the display.

Radio Interface Menu

Selects the radio to be connected to the Radio Interface connector. Select `ALINCO/ICOM` to interface with radios that are compatible with the Alinco EDX-2 tuner, Icom AH-3 and AH-4 tuners. Select `KENWOOD AT-300` to interface with radios that are compatible with Kenwood AT-300 tuner. Select `YAESU FC-30` to interface with radios that are compatible with Yaesu FC-30 tuner and Yaesu FT-100. Select `YAESU MF/2K/9K` to interface with the Yaesu FT-1000MP series, FT-2000 series, FTDX-9000 series, and any radios that are compatible with Yaesu FH-1 or FH-2 remote control. If no connection is connected to the Radio Interface connector, select `OFF` to disable the interface. See “Radio Interface” section on pages 10 to 13 for more information. Default is OFF.

Note: When exiting the setup mode, *TURN POWER OFF* message will display if the Radio Interface menu setting has changed. Turn the tuner's power off, connect the new radio interface, then on again to re-initialize the radio interface circuitry.

Note: If the wrong interface is selected and the *TURN ON RADIO* message does not go away, disable the interface by pressing and holding both [TUNE] and [MODE] while turning on the power. The tuner will respond with two beeps. Then select the correct interface.

Push Tune <0.5s Menu

Selects how the [TUNE] button behaves when it is pressed momentarily. Refer to the "Tune Button" section on page 8 for more details. Default is TO BYPASS.

LC Limit Menu

The upper limits of inductance (L) and capacitance (C) are factory-limited according to frequency and maximum power rating; i.e., higher frequencies need less inductance and less capacitance when the L-network is properly tuned. Pressing [C-UP] and/or [L-UP] allows capacitance and inductance to be increased only to these limits. When a selected capacitance or inductance is higher than its allowed limit, and the frequency is changed, that selection is automatically reduced to the value of its limit. These limits are used to prevent matching of extreme load impedance outside the tuner's specification, which may result in excess voltage and/or current across the tuner's components. This setting is not stored in non-volatile memory and reverts back to the default when the tuner power is cycled. Refer to Figures 16 and 17 for the on-screen LC Limit indicator. Default is ON.

Note: If this feature is turned OFF, it will be re-set to ON whenever power is cycled.

WARNING: LC Limit is a safety precaution; the tuner is in danger of being damaged if this function is turned off.

Operation

Manual Tuning

Note: Manual tuning must only be attempted under low power (less than 20 watts) conditions.

Manual tuning may be used to "touch up" the tuner's settings. For example, if the target SWR is set at the default of 1.5, the tuner will stop when a match of 1.5 is found. In all cases, manual tuning gives the user control of the tuner if desired, and the L-Network menu provides a picture of the matching network configuration. Manual tuning should always be done at low power, and is accomplished by using the [C-UP], [C-DN], [L-UP], and [L-DN] buttons. Since it is not known if more or less capacitance or inductance is needed, manual tuning must be by trial-and-error. As an example, to manually tune capacitance, press [C-UP] one time, and the reflected power will indicate if [C-UP] was the right "direction." If it was, press [C-UP] again and observe reflected power. If not, press [C-DN] twice (once to return to the original setting of C, and once for one click past it).

Manual tuning of inductance is similarly accomplished, using [L-UP] and [L-DN]. Since the capacitance and inductance are interdependent, some back-and-forth between the two may be needed, just as in a conventional tuner with knobs.

Pressing [C-UP] and [C-DN] simultaneously moves the capacitance back and forth from one side of the inductance to the other. The L-Network menu displays the capacitance on the left to indicate that the capacitance is on the antenna side (corresponding with the rear panel configuration of connectors); the capacitance value moves to the right side of the display when the capacitance is on the transmitter side of the inductance. A general rule of thumb is that loads with impedance higher than 50 ohms call for the capacitance on the antenna side; loads with impedance lower than 50 ohms call for the capacitance on the transmitter side.

Pressing [C-DN] and [L-DN] simultaneously or pressing [TUNE] quickly places the tuner in bypass mode; i.e. zero inductance and zero capacitance. RF from the transmitter goes directly to the antenna with no matching. One beep indicates changing to bypass mode. Also, the decimal point in the SWR reading is replaced with a comma to indicate bypass mode.

Pressing [TUNE] and [ANT] simultaneously toggles between automatic or semi-automatic tuning mode. In automatic mode, the tuning routine is automatically started when at least five watts of power is applied and the SWR is a preset amount above the preset target SWR. In semi-automatic mode, the tuning routine starts only when the [TUNE] button is pressed. The Auto/Semi indicator on the main display indicates the selected mode.

Pressing [TUNE], [C-DN] and [L-DN] simultaneously overwrites the tuner memory with the current tuner setting. Settings with SWR greater than 3.0 will not be stored. One beep indicates memory overwrite.

Morse Code and Beeps

If insufficient power is applied for tuning (less than five watts), the display will flash **INCREASE POWER** three times and “QRO” (dah-dah-di-dah di-dah-dit dah-dah-dah) will be sent on CW. Increasing the input power above five watts ends this message.

When input power is too high, the tuner enters a self-protection mode. The tuner will not allow any of its relays to change to prevent damage to your tuner.

If too much power is applied when tuning, the tuner will cease the tuning routine, flash **DECREASE POWER** three times and send “QRP” (dah-dah-di-dah di-dah-dit di-dah-dah-dit) on CW. This occurs when the forward power exceeds 75 watts and the SWR is greater than 3.0, or when the forward power exceeds 125 watts regardless of the SWR.

If more than 1500 watts is applied to the tuner, the tuner will go into bypass mode, flash **OVERLOAD** three times and send “QRT” (dah-dah-di-dah di-dah-dit dah) on CW.

If the tuning process is activated under these conditions, the tuner will not start the tuning. It will display a warning message on the LCD and send the appropriate code on CW. The following table shows the various tuner beeps:

Function	Indicates By One Beep			Indicates By Two Beeps		By Pressing
Antenna	1			2		[ANT] < 1 second
Memory Bank	Bank A (1 beep)	Bank B (2 beeps)	Bank C (3 beeps)	Bank D (4 beeps)	Off (5 beeps)	[ANT] > 1 second
Bypass Toggle	Bypass Mode (L = 0 and C = 0)		Restore Last L/C Setting			[TUNE] < 0.5 second [C-DN] + [L-DN]
Tuned SWR	SWR ≤ 1.5 (1 beep)	SWR ≤ 2.0 (2 beeps)	SWR ≤ 2.5 (3 beeps)	SWR ≤ 3.0 (4 beeps)	SWR > 3.0 ("SWR")	[TUNE] for 0.5 to 2 seconds
StickyTune™	On			Off		[TUNE] for 2 to 10 seconds
[TUNE] < 0.5 sec.	To Bypass			To Tune		[TUNE] > 10 seconds
Manual L/C Adjustment	L/C at Lower Limit			L/C at Upper Limit		[C-DN] or [L-DN] [C-UP] or [L-UP]
Capacitors	Switch to Antenna Side			Switch to Transmitter Side		[C-UP] + [C-DN]
Tuning Mode	Automatic			Semi-Automatic		[TUNE] + [ANT]
Memory Overwrite	X					[TUNE] + [C-DN] + [L-DN]
Amplifier Bypass Control™	On			Off		[MODE] + [L-UP] + [L-DN]
Disable Radio Interface				X		[TUNE] + [MODE] + [POWER]
Delete Confirmation? DELETE BANK DELETE ANTENNA TOTAL RESET	Yes DELETED or RESET			No CANCEL		[C-DN] for YES or [L-DN] for NO

Table 2. Tuner Beeps.

Transceiver Foldback

Modern transceivers with solid-state finals usually have a foldback circuit to protect the final transistors from damage due to high SWR. A foldback circuit detects the SWR during transmit and reduces the output power as the SWR rises above a preset threshold, usually 2:1. The higher the SWR the lower the power is set to prevent damage.

If your transceiver has a foldback circuit, you can simply key down and tune at any power level from 5 to 100 watts. If your transceiver does not have a foldback circuit, you should manually set the power level to 10-30 watts for tuning. At higher power levels, the reflected power that occurs during tuning can damage your transceiver or amplifier and causes component arcing which can damage the relays in the tuner.

Check your transceiver owner's manual to see if it has a foldback circuit. When an amplifier is used, the amplifier must be bypassed during tuning.

Note: MFJ recommends that a transceiver-specific interface cable be used between the MFJ-998 and your transceiver, and that an amplifier enable/bypass connection be used between the MFJ-998 and your amplifier, to ensure that tuning only occurs at low power.

Grounding Hints

To minimize RFI, single wire feedlines (such as used with Windom or longwire antennas) should be kept away from other wiring. Radiation will be minimized if the single wire feeder runs parallel and reasonably close to the wire that connects the tuner to the outdoor ground. The antenna feed wire should be adequately insulated to prevent arcing or accidental contact.

CAUTION

For operator safety, a good outside earth ground or water pipe ground should always be installed and connected to the case of the MFJ-998. Make certain the safety ground also connects to the transmitter and other station accessories. A wing-nut post marked GROUND is provided for ground connections. Most building codes also require that all grounds be connected with the main utility ground where power enters your home.

For safety, always use good DC and RF grounds. It is particularly important to have a good RF ground when using a single wire feeder since the tuner needs something to "push" against in order to force current into the single wire feedline. If a good RF ground is not available, RF will usually find its way back into the power line (RFI), transmitter audio circuits (RF feedback), or the operator (RF burns).

Metal water pipes and ground rods provide good DC and AC safety grounds, but they are almost useless for dependable RF grounding.

RF grounds work much better when "spread out" over a large area, especially when they employ multiple connections directly to the equipment ground point. Metal water pipes, heating ducts, and fences may work (especially if they are connected together with multiple wires), but the best RF grounds are radial systems or multi-wire counterpoises. Radials and counterpoises provide large, low resistance surfaces for RF energy.

RF and lightning travel on the surface of conductors. Braided or woven conductors have high surface resistance to lightning and RF. Ground leads for RF and lightning should have wide smooth surfaces. Avoid the use of woven or braided conductors in RF and lightning grounds unless the lead needs to be flexible.

Antenna System Hints

Coaxial Cable Selection

The proper selection of coax cable will minimize antenna system losses, especially in the presence of high SWR. And the coax cable selection is particularly important in high power amateur installations. RG-58/U or RG-8X is fine for interconnecting the transceiver output and amplifier input. However, these cable types are unacceptable at the amplifier output and tuner output due to power handling capability and loss – especially loss in the presence of high SWR. As an example, RG-58/U has a maximum power handling capability of 570 watts and loss of 2.4 dB/100 feet at 28 MHz under matched conditions, while the maximum power for RG-8X is just 360 watts with a loss of 1.9 dB/100 feet at 28 MHz under matched conditions. When the SWR rises, the power handling capability decreases by $1/\sqrt{\text{SWR}}$ and loss also increases. Therefore MFJ recommends that RG-8/U, RG-213, LMR-400 or other high quality coax cables be used between the MFJ-998 output and the antenna. Refer to The Radio Amateurs Handbook and The ARRL Antenna Book for more information.

Location

For the best performance, an end-fed longwire wire antenna should be at least one quarter-wavelength long at the operating frequency. Horizontal dipole antennas should be at least a half-wavelength long and

located as high and clear as possible. While good RF grounds help the signal in almost any transmitting installation, it is extremely important to have good RF grounds with long wire or other Marconi-style antennas.

Matching Problems

Most matching problems occur when the antenna system presents an extremely high impedance to the tuner. When the antenna impedance is much lower than the feedline impedance, an *odd quarter-wavelength* feedline converts the low antenna impedance to a very high impedance at the tuner. A similar problem occurs if the antenna has an extremely high impedance and the transmission line is a multiple of a half-wavelength. The half-wavelength line *repeats* the very high antenna impedance at the tuner. Incorrect feedline and antenna lengths can make an otherwise perfect antenna system very difficult or impossible to tune.

One example where this problem occurs is on 80 meters when an odd quarter-wave (60 to 70 feet) open wire line is used to feed a half-wave (100 to 140 feet) dipole. The odd quarter-wave line transforms the dipole's low impedance to over three thousand ohms at the tuner. This is because the mismatched feedline is an *odd multiple* of 1/4 wavelength long. The line *inverts* the antenna impedance.

A problem also occurs on 40 meters with this same antenna example. The feedline is now a multiple of a half-wave (60 to 70 feet) and connects to a full-wave high impedance antenna (100 to 140 feet). The half-wave line repeats the high antenna impedance at the tuner. The antenna system looks like several thousand ohms at the tuner on 40 meters. This places enormous strain on the tuner, since voltages can reach several thousand volts. This can cause component arcing and heating.

The following suggestions will reduce difficulty in matching an antenna with a tuner:

- Never center feed a half-wave multi-band antenna with a high impedance feedline that is close to an odd multiple of a quarter-wave long.
- Never center feed a full-wave antenna with a feedline close to a multiple of a half-wave long.
- If this tuner will not "tune" a multi-band antenna, add or subtract 1/8 wave of feedline (for the band that won't tune) and try again.
- Never try to load a G5RV or center fed dipole on a band below the half-wave design frequency. If you want to operate an 80-meter antenna on 160 meters, feed either or both conductors as a longwire against the station ground.

To avoid problems matching or feeding any dipole antenna with high impedance open wire lines, keep the lines around these lengths. [The *worst possible* line lengths are shown in brackets]:

160 meters dipole:	35-60, 170-195 or 210-235 feet	[Avoid 130, 260 ft]
80 meters dipole:	34-40, 90-102 or 160-172 feet	[Avoid 66, 135, 190 ft]
40 meters dipole:	42-52, 73-83, 112-123 or 145-155 feet	[Avoid 32, 64, 96, 128 ft]

Some slight trimming or adding of feedline may be necessary to accommodate the higher bands.

WARNING

To avoid problems, a dipole antenna should be a full half-wave on the lowest band. On 160 meters, an 80 or 40 meters antenna fed the normal way will be extremely reactive, with only a few ohms of feedpoint resistance. Trying to load an 80 meters half-wave dipole (or shorter) antenna on 160 meters can be a disaster for both your signal and the tuner. The best way to operate 160 meters with an 80 or 40 meters antenna is to load either or both feedline wires (in parallel) as a longwire. The antenna will act like a "T" antenna worked against station ground.

Appendices

POWER-ON OPERATIONS
(Press and hold buttons while turning on the power.)

Press and hold	TUNE				+ POWER to start the self test.
Press and hold	C-DN				+ POWER to test the relays.
Press and hold		L-DN			+ POWER to test the power-down circuitry.
Press and hold	TUNE	+ MODE			+ POWER to disable the radio interface.
Press and hold	TUNE	+ ANT			+ POWER to delete current antenna memory.
Press and hold	TUNE	+ C-UP			+ POWER to delete current memory bank.
Press and hold	TUNE		+ L-UP		+ POWER to reset factory defaults.
Press and hold	TUNE	+ C-UP	+ L-UP		+ POWER to perform total reset.
Press and hold		C-UP	+ C-DN		+ POWER to calibrate the analog meter.
Press and hold		C-UP	+ L-UP		+ POWER to calibrate the SWR bridge.
Press and hold		C-DN	+ L-DN		+ POWER to calibrate the frequency counter.

Figure 18. Power-On Operations.

Resetting the Tuner

Each time the tuner is powered off, the microprocessor saves all memories and configurations to non-volatile memory ready to be used the next time the unit is turned on and transmit power is applied. If the tuner is not working properly, even on initial power on, try resetting to the factory defaults.

Factory Defaults

The unit is shipped with the following default settings:

- Main Menu Digital Wattmeter
- Setup Menu Target SWR
- Inductance 0 μH
- Capacitance 0 pF
- Antenna 1
- Tuning Mode Automatic †
- Target SWR 1.5 †
- Auto Tune SWR 0.5 above target SWR †
- Amp Bypass SWR 2.0 †
- Meter Range Auto range †
- Peak Hold On †
- Memory Banks 1A and 2A on †
- IntelliTune On †
- SWR Beep Off

- Beep On
- Refresh Off
- Radio Interface Off
- Push Tune <0.5s To Bypass

† These settings are stored separately for antennas 1 and 2.

Note: *Resetting to factory defaults does not erase the antenna memories.*

To reset the tuner to these defaults:

1. Turn off the power to the tuner.
2. Press and hold *both* the [TUNE] and [L-UP] buttons while turning the power on.
3. Release the buttons when DEFAULTS RESET appears on the display.
4. Resume normal operation.

WARNING: If the MFJ-998 is not behaving properly or is acting erratically, try resetting the tuner to factory defaults.

Disable Radio Interface

If the wrong radio interface is selected and the TURN ON RADIO message does not go away, disable the interface by pressing and holding *both* [TUNE] and [MODE] buttons while turning the power on. The tuner will respond with two beeps. Then enter the setup mode to select the correct radio interface.

Delete Entire Antenna Memory

To delete an entire antenna memory (all four banks), select Antenna 1 or Antenna 2 with the [ANT] button that you want to delete. Turn off power to the tuner, and then press and hold *both* the [TUNE] and [ANT] buttons while turning the power back on. A confirmation message DELETE ANTENNA will display. Press the YES [C-DN] button to delete the antenna memory (a progress bar and DELETED will display), or press the NO [L-DN] button to cancel (CANCEL will display). Release the button to resume normal operation. Remember that the selected antenna memory will be lost!

Delete Antenna Memory Bank

To delete an antenna memory bank, select Antenna 1 or Antenna 2 and the antenna memory bank with the [ANT] button that you want to delete. Turn off power to the tuner, and then press and hold *both* the [TUNE] and [C-UP] buttons while turning the power back on. A confirmation message DELETE BANK will display. Press the YES [C-DN] button to delete the antenna memory (a progress bar and DELETED will display), or press the NO [L-DN] button to cancel (CANCEL will display). Release the button to resume normal operation. Remember that the selected antenna memory bank will be lost!

Total Reset

To erase *both* antenna memories and reset to factory defaults, press and hold down the [TUNE], [C-UP] and [L-UP] buttons while turning the power on. A confirmation message TOTAL RESET will display. Press the YES [C-DN] button to delete both antenna memories and reset factory defaults (a progress bar and RESET will display), or press the NO [L-DN] button to cancel (CANCEL will display). Release the button to resume normal operation. Remember that both antenna memories will be lost!

Self Test

A self-test routine will check the functions of the MFJ-998. This routine checks the display, the front-panel buttons, the internal memory, the audio circuitry, and the power-down circuitry. During the self-test, you may stop the test by turning off the unit; however, this should NOT be done during the memory test or the memory could be corrupted. The self-test can be completed in approximately 30 seconds.

Note: *Performing the self-test will reset the unit to its factory default settings.*

Here is the self-test procedure:

1. Turn off the power to the tuner.
2. Unplug the radio interface cable, if one is connected, from the tuner.
3. Press and hold *only* the [TUNE] button while turning the power on.
4. The test begins by displaying a copyright message and firmware version numbers, such as
COPYRIGHT (c) 2007-2010 MFJ ENTERPRISES, INC. VERSION YYWW.BB.RR.
This is the test of the display. Release the [TUNE] button before the message completes.
5. You will be prompted to press each of the front-panel buttons: [ANT], [MODE], [C-UP], [C-DN], [L-UP], [L-DN] and [TUNE].
6. The unit then tests its non-volatile memory. Notice this step will reset the unit to its factory default settings.
7. If the unit is okay, a repetitive message **PASS** will be displayed and sent as Morse code (di-dah-dah-dit di-dah di-di-dit di-di-dit). If there is a problem, a failure message will be displayed and sent repetitively.
8. Once you have confirmed that the audio is okay, turn the unit off.
9. Turn the unit on again to test the power-down detection circuitry.
10. If the power-down detection circuitry is okay, a repetitive message **PASS** will be displayed and sent as Morse code (di-dah-dah-dit di-dah di-di-dit di-di-dit). If there is a problem, message **PD FAIL** will be displayed and sent as Morse code repetitively.
11. Turn the power off.

Failure Message	Indicates
ANT FAIL	[ANT] button is shorted or improperly connected.
MODE FAIL	[MODE] button is shorted or improperly connected.
C-UP FAIL	[C-UP] button is shorted or improperly connected.
C-DN FAIL	[C-DN] button is shorted or improperly connected.
L-UP FAIL	[L-UP] button is shorted or improperly connected.
L-DN FAIL	[L-DN] button is shorted or improperly connected.
TUNE FAIL	[TUNE] button is shorted or improperly connected.
MEMORY FAIL	Non-volatile memory circuitry is improperly connected.
WAKEUP FAIL	Microprocessor wakeup circuitry problem.
PD FAIL	Power-down circuitry problem.

Table 3. Failure Messages.

Power-Down Circuit Test

When the 12 VDC power to the tuner is turned off, the tuner saves all settings to non-volatile memory. The Power-Down Circuit Test checks the power down detection circuitry. It is recommended that this test be done immediately after the regular self-test described above.

Note: *The tuner must be reset to factory defaults before performing this test.*

Here is the test procedure:

1. Make sure power to the tuner is off.
2. If the tuner has been reset to factory defaults, skip to step 6; otherwise continue with step 3.
3. Press and hold *both* the [TUNE] and [L-UP] buttons while turning the power on.
4. Release the buttons when DEFAULTS RESET appears on the display.
5. Turn the power off.
6. Press and hold *only* the [L-DN] button while turning the power on.
7. If the power-down detection circuitry is okay, a repetitive message PASS will be displayed and sent as Morse code (di-dah-dah-dit di-dah di-di-dit di-di-dit). If there is a problem, message PD FAIL will be displayed and sent as Morse code repetitively.
8. Turn the power off.

Relay Test

WARNING: Turn off the transmitter power or disconnect the transmitter before performing this test; otherwise, damage to the tuner can result.

To test the relays and their control circuitry, press and hold the [C-DN] button while turning the power on. The message RELAY TEST will appear. Six numbers representing the relays will be shown on the display. The [ANT], [C-UP], [L-UP], [MODE], [C-DN] and [L-DN] buttons, corresponding to the position of the relay numbers on the display, are used to toggle each relay on and off. Press button to engage the relay and release it to disengage the relay. Listen for relay clicks. Press the [TUNE] button to proceed to the next group of six relays. There are 31 relays in the tuner. Repeat the above procedure to test all the relays. Normal operation is resumed after this test.

Analog Meter Calibration

To calibrate the analog meter, you will need a tuning tool or small flat blade screwdriver.

1. Turn off the power to the tuner and the transmitter.
2. Press and hold *both* the [C-UP] and [C-DN] buttons while turning the power on.
3. A message CAL WATTMETER TO ZERO SCALE will display. Adjust the two zero adjustment screws, located below the analog meter, to set both the forward and reflected needles to the 0-watt marks.
4. Press the [TUNE] button to calibrate the needles to full scales.
5. A message CAL WATTMETER TO FULL SCALE will display. Adjust the two trimpots, located on the left side of the LCD display, to set the forward and reflected needles to the 300-watt and 60-watt marks, respectively.
6. Press the [TUNE] button to end calibration and resume normal operation.

SWR Bridge Calibration

To calibrate the SWR Bridge, you will need a transmitter capable of 100 watts output, a precise calibrated wattmeter, a 50-ohm dummy load, three 50-ohm SO-239 coax cables, a Phillips screwdriver, and a tuning tool or small flat blade screwdriver.

WARNING: Do not touch anything inside the tuner during operation! Serious, painful RF burns can result.

WARNING: Never operate the MFJ-998 with its cover removed; dangerous voltages and currents can be present during operation. Never exceed tuner specifications.

1. Turn off the power to the tuner and the transmitter.
2. Remove the cover from the tuner (12 screws) with a Phillips screwdriver.
3. Connect the 50-ohm dummy load to the ANTENNA 1 connector; connect the wattmeter between the transmitter and the TRANSMITTER connector on the tuner.
4. Turn on the power to the transmitter. Using a frequency in the middle of the HF band, such as 7.253 MHz, for calibration is recommended.
5. Press and hold *both* the [C-UP] and [L-UP] buttons while turning the tuner power on.
6. A message `CAL CAP AND FWD` will display. Key the transmitter to output 100 watts and adjust trimmer capacitor VC1 (located on the small circuit board mounted in front of the TRANSMITTER connector) for minimum reflected power. Notice the reflected meter movement is exaggerated for easier calibration.
7. Key the transmitter to 100 watts output and adjust the FWD trimpot VR1 (located next to the big integrated circuit) until the display shows forward power of `FWD=100` watts. The forward meter also should indicate 100 watts.
8. Press the [TUNE] button. A message `REVERSE, CAL REF` displays and the reflected meter goes to full scale.
9. Turn off the transmitter and reverse the ANTENNA 1 and TRANSMITTER connections; that is, connect the 50-ohm dummy load to the TRANSMITTER connector and connect the transmitter/wattmeter to the ANTENNA 1 connector.
10. Turn on the transmitter's power.
11. Key the transmitter to 100 watts output and adjust the REF trimpot VR2 (located next to the big integrated circuit) until the display shows reflected power of `REF=100` watts. The forward meter (yes, the forward meter) also should indicate 100 watts; the reflected meter is at full scale.
12. Press the [TUNE] button to end calibration.
13. Turn off the power to the tuner and the transmitter.
14. Remove the transmitter/wattmeter and the 50-ohm dummy load from the tuner.
15. Secure the cover back onto the tuner.
16. Connect your transmitter to the TRANSMITTER connector and connect your antenna to the appropriate antenna connector on the tuner.

Frequency Counter Calibration

To calibrate the frequency counter, you will need a transmitter, a 50-ohm dummy load, two 50-ohm SO-239 coax cables, a Phillips screwdriver, and a tuning tool or small flat blade screwdriver.

WARNING: Do not touch anything inside the tuner during operation! Serious, painful RF burns can result.

WARNING: Never operate the MFJ-998 with its cover removed; dangerous voltages and currents can be present during operation. Never exceed tuner specifications.

1. Turn off the power to the transmitter and the tuner.
2. Remove the cover from the tuner (12 screws) with a Phillips screwdriver.
3. Connect the 50-ohm dummy load to the ANTENNA 1 connector; connect the transmitter to the TRANSMITTER connector on the tuner.
4. Turn on the power to the transmitter. Set and lock the frequency to *exactly* 29.000 MHz.
5. Press and hold *both* the [C-DN] and [L-DN] buttons while turning the tuner power on. Both meter needles will go to full scale and a message `CAL FREQ 29.000` will display.
6. Key the transmitter to output about 10 watts. Adjust trimmer capacitor VC2 (located next to the big integrated circuit) until the tuner displays a frequency of `29.000MHz` and the meter needles settle at the 0-watt marks. Notice the meter movement is exaggerated for easier calibration. Nominal tolerance of the frequency counter is ± 1 kHz.
7. Turn off the power to the transmitter and the tuner.
8. Secure the cover back onto the tuner.

Alinco Radio Interface

The MFJ-5114A radio interface allows users of EDX-2 compatible Alinco transceivers to connect to the MFJ-998 *IntelliTuner*™ Automatic Antenna Tuner. With this interface, control signals are connected between the radio and the tuner. The operator can then control the tuner with a single push of the [TUNE] button on the front panel of the radio. Supported Alinco radios are DX-70, DX-77, DX-701, DX-801, and any Alinco radio that supports the Alinco EDX-2 tuner.

Connections

1. Select **ALINCO/ICOM** in the tuner's Radio Interface setup menu. Turn the tuner off.
2. Insert the 8-pin modular plug into the tuner's RADIO INTERFACE jack.
3. **Important:** *Make sure the DC power to the radio has been turned off. The radio does not fuse the DC power to the tuner, and damage to the radio can occur if the interface's power connection comes in contact with ground.*
4. Connect the 5-pin molex connector to the mating 5-pin molex connector, marked as ACC, on the back of the Alinco radio.
5. Connect a 12V 1.5 amp DC source to the MFJ-998.
6. Push the [POWER] button on the tuner to the *in* position and then power on the radio.

Operation

The operation of the MFJ-5114A radio interface is similar to the operation of the EDX-2 described in the Alinco operating manual.

1. Push the [TUNE] button on the radio to initiate automatic tuning process; for DX-70 press [FUNC] then [TUNE]. The radio will automatically switch to CW mode, transmit a 10-watt carrier, and start the tuning process. "TUNE" appears in the radio's LCD while tuning; do not change the frequency or mode while tuning. When the tuning process is completed, the radio will stop transmitting, return to its previous mode and power setting; "TUNE" disappears.

Note the [TUNE] button on the tuner will also key the Alinco radio interface.

Icom Radio Interface

The MFJ-5114I radio interface allows users of AH-3 or AH-4 compatible Icom transceivers to connect to the MFJ-998 *IntelliTuner*[™] Automatic Antenna Tuner. With this interface, control signals are connected between the radio and the tuner. The operator can then control the tuner with a single push of the [TUNER] button on the front panel of the radio. Supported Icom radios are IC-706, IC-707, IC-718, IC-725, IC-728, IC-736, IC-738, IC-746, IC-756, IC-7000, and any Icom radio that supports the Icom AH-3 or AH-4 tuner.

Connections

1. Select **ALINCO/ICOM** in the tuner's Radio Interface setup menu. Turn the tuner off.
2. **For IC-7000, make sure jumper JP1 inside the MFJ-998 is removed.**
3. Insert the 8-pin modular plug into the tuner's RADIO INTERFACE jack.
4. **Important:** *Make sure the DC power to the radio has been turned off. The radio does not fuse the DC power to the tuner, and damage to the radio can occur if the interface's power connection comes in contact with ground.*
5. Connect the 4-pin molex connector to the mating 4-pin molex connector, marked as TUNER, on the back of the Icom radio.
6. Connect a 12V 1.5 amp DC source to the MFJ-998.
7. Push the [POWER] button on the tuner to the *in* position and then power on the radio.
8. Some Icom radios, such as the IC-706, automatically check to see if an external antenna tuner is connected during power on. For other Icom radios, such as the IC-718, the Tuner Type menu in the radio menu system must be enabled. Refer to your radio's operating manual for accessing the menu system and preparing the AH-4 antenna tuner operation. Use IC-718 as an example:
 - a. Push [PWR] for 1 second to turn power off.
 - b. While pushing and holding [SET], push [PWR] to turn power on.
 - c. Push [UP] or [DN] one or more times to select TUNER.
 - d. Rotate the Main Dial to select "4" for AH-4 antenna tuner.
 - e. Push [PWR] for 1 second to turn power off.
 - f. Push [PWR] to turn power on again.

Operation

The operation of the MFJ-5114I radio interface is similar to the operation of the AH-3 or AH-4 described in the Icom radio's operating manual.

1. Push and hold the [TUNER] button on the radio for one or two seconds to initiate automatic tuning process. The radio will automatically switch to CW mode, transmit a 10-watt carrier, and start the tuning process. When the tuning process is completed, the radio will stop transmitting, return to its previous mode and power setting.
2. Push the [TUNER] button on the radio quickly to bypass the tuner or to cancel tuning in progress.

Note the [TUNE] button on the tuner will also key the Icom radio interface.

Kenwood Radio Interface

The MFJ-5114K radio interface allows users of AT-300 compatible Kenwood transceivers to connect to the MFJ-998 *IntelliTuner*™ Automatic Antenna Tuner. With this interface, control signals are connected between the radio and the tuner. The operator can then control the tuner with a single push of the [AT TUNE] button on the front panel of the radio. Supported Kenwood radios are TS-50S, TS-450S, TS-480HX, TS-570S, TS-690S, TS-850S, TS-870S, TS-2000, and any Kenwood radio that supports the Kenwood AT-300 tuner.

Note: *The TS-480HX will automatically reduce its TX power to 100 watts maximum (25 watts AM) when the radio interface is used.*

Connections

1. Select **KENWOOD AT-300** in the tuner's Radio Interface setup menu. Turn the tuner off.
2. Make sure jumper JP1 inside the MFJ-998 is installed.
3. Insert the 8-pin modular plug into the tuner's RADIO INTERFACE jack.
4. **Important:** *Make sure the DC power to the radio has been turned off. The radio does not fuse the DC power to the tuner, and damage to the radio can occur if the interface's power connection comes in contact with ground.*
5. Connect the 6-pin molex connector to the mating 6-pin molex connector, marked as AT or ACC, on the back of the Kenwood radio.
6. Connect a 12V 1.5 amp DC source to the MFJ-998.
7. Push the [POWER] button on the tuner to the *in* position and then power on the radio.
8. Some Kenwood radios automatically check to see if an external antenna tuner is connected during power on. For other Kenwood radios, such as the TS-450S and the TS-690S, the External Antenna Tuner menu in the radio menu system must be enabled. Refer to your radio's operating manual for accessing the menu system and preparing the AT-300 external antenna tuner operation. Use TS-450S and TS-690S as an example:
 - a. Press and hold the [ENT] key while turning the power on.
 - b. Rotate the [M.CH/VFO CH] control to select menu number 01 on the display.
 - c. Press the [UP] or [DOWN] key to change the setting to "ON."
 - d. Press the [CLR] key to return to normal operation.

Operation

The operation of the MFJ-5114K radio interface is similar to the operation of the AT-300 described in the Kenwood radio's operating manual.

1. Press and hold the [AT TUNE] button on the radio for one second to initiate automatic tuning process. The radio will automatically switch to CW mode, transmit a 10-watt carrier, and start the tuning process. When the tuning process is completed, the radio will stop transmitting, return to its previous mode and power setting.
2. Press the [AT TUNE] button on the radio quickly to bypass the tuner (some Kenwood radios, such as the TS-690S, do not have this bypass function) or to cancel tuning in progress.

Note the [TUNE] button on the tuner will not operate the Kenwood radio interface.

Yaesu Radio Interface/MFJ-5114Y

The MFJ-5114Y radio interface allows users of FC-30 compatible Yaesu transceivers to connect to the MFJ-998 *IntelliTuner*™ Automatic Antenna Tuners. With this interface, control signals are connected between the radio and the tuner. The operator can then control the tuner with a single push of the (TUNE) key on the front panel of the radio. Supported Yaesu radios are FT-100, FT-450, FT-857, FT-897, FT-950, and any Yaesu radio that supports the Yaesu FC-30 tuner.

Connections for FT-100

1. Select **YAESU FC-30** in the tuner's Radio Interface setup menu. Turn the tuner off.
2. Make sure jumper JP1 inside the MFJ-998 is installed.
3. Before connecting the MFJ-5114Y to your radio, follow the instructions in the radio's manual for installing the FC-20 automatic antenna tuner.
 - a. Press and hold the [FUNC] key for ½ second to activate the Menu mode.
 - b. Rotate the [SELECT] knob to recall Menu #61 [TUNER/ATAS], and then rotate the Main Dial to change the setting to "tunEr."
 - c. Press the [FUNC] key momentarily to save the new setting and exit to normal operation.
 - d. Turn the FT-100's power off, then on again, to re-initialize the radio regarding the tuner status.
4. Turn the radio off. Insert the 8-pin modular plug into the tuner's RADIO INTERFACE jack.
5. **Important:** *Make sure the DC power to the radio has been turned off. The radio does not fuse the DC power to the tuner, and damage to the radio can occur if the interface's power connection comes in contact with ground.*
6. Connect the 8-pin mini DIN connector to the mating 8-pin mini DIN connector at the end of the BAND DATA cable pigtail on the back of the radio.
7. Connect a 12V 1.5 amp DC source to the MFJ-998.
8. Push the [POWER] button on the tuner to the *in* position and then power on the radio.

Operation for FT-100

The operation of the MFJ-5114Y radio interface is similar to the operation of the FC-20 described in the Yaesu radio's operating manual.

1. Press the [FUNC] key, as needed, to recall Operating Function Row 7 [MTR, TUN, PRO, VOX].
2. Press the [B](TUN) key on the radio for ½ second to turn the external tuner function on; the "TUN" icon will appear bolded in the radio's display.
3. Press and hold the [B](TUN) key on the radio to begin automatic tuning. The radio will automatically transmit a low-power carrier and start the tuning process. Press the [B](TUN) key again to cancel tuning in progress. When tuning is completed, the radio will stop transmitting and you will be ready for operation on this frequency.

Note the [TUNE] button on the tuner will not operate the MFJ-5114Y Yaesu radio interface.

Connections for FT-450

1. Select **YAESU FC-30** in the tuner's Radio Interface setup menu. Turn the tuner off.
2. Make sure jumper JP1 inside the MFJ-998 is installed.
3. Before connecting the MFJ-5114Y to your radio, follow the instructions in the radio's manual for installing the FC-30/-40 automatic antenna tuner.
 - a. Press and hold the [F] button for one second to enter the Menu mode. The "MENU" icon will appear in the display.
 - b. Rotate the [DSP/SEL] knob to select Menu item [TUNER (TUNER/ATAS)].
 - c. Press the [DSP/SEL] knob to enable this selected Menu item.
 - d. Rotate the [DSP/SEL] knob to change the setting to "EXT ATU."
 - e. Press and hold the [F] button for one second to save the new setting and exit to normal operation.
4. Turn the radio off. Insert the 8-pin modular plug into the tuner's RADIO INTERFACE jack.
5. **Important:** *Make sure the DC power to the radio has been turned off. The radio does not fuse the DC power to the tuner, and damage to the radio can occur if the interface's power connection comes in contact with ground.*
6. Connect the 8-pin mini DIN connector to the mating 8-pin mini DIN connector, marked as TUNER, on the back of the radio.
7. Connect a 12V 1.5 amp DC source to the MFJ-998.
8. Push the [POWER] button on the tuner to the *in* position and then power on the radio.

Operation for FT-450

The operation of the MFJ-5114Y radio interface is similar to the operation of the FC-30/-40 described in the Yaesu radio's operating manual.

1. Press the (TUNE) button on the radio briefly to enable the external tuner function. The "TUNER" icon will appear in the radio's display. If the radio frequency is out of the amateur band, the "TUNER" icon will not appear.
2. Press and hold the (TUNE) button on the radio for one second to begin automatic tuning. The radio will automatically transmit a low-power carrier and start the tuning process. The "TUNER" icon will blink while tuning is in progress. Press and hold the (TUNE) button on the radio for one second while tuning is in progress to cancel the automatic tuning.
3. When tuning is completed, the radio will stop transmitting and you will be ready for operation on this frequency.

Note the [TUNE] button on the tuner will not operate the MFJ-5114Y Yaesu radio interface.

Connections for FT-857 or FT-897

1. Select ~~YAESU FC-30~~ in the tuner's Radio Interface setup menu. Turn the tuner off.
2. Make sure jumper JP1 inside the MFJ-998 is installed.
3. Before connecting the MFJ-5114Y to your radio, follow the instructions in the radio's manual for installing the FC-30 automatic antenna tuner. For the following, use the [FUNC] key and the [SELECT] knob on the FT-857, or use the [F] key and the [MEM/VFO CH] knob on the FT-897.
 - a. Press and hold the [FUNC] or [F] key for one second to activate the Menu mode.
 - b. Rotate the [SELECT] or [MEM/VFO CH] knob to recall Menu Mode #001 [EXT MENU], and then rotate the Main Dial to change the setting to "ON" to enable extended Menu Mode.
 - c. Rotate the [SELECT] or [MEM/VFO CH] knob to recall Menu Mode #020 [CAT/LIN/TUN], and then rotate the Main Dial to change the setting to "TUNER."
 - d. Press and hold the [FUNC] or [F] key for one second to save the new setting and exit to normal operation.
 - e. Turn the radio off, then on again. Do not connect the MFJ-5114Y before changing the Menu Mode #020 [CAT/LIN/TUN].
 - f. Press and hold the [FUNC] or [F] key for one second to activate the Menu mode.
 - g. Rotate the [SELECT] or [MEM/VFO CH] knob to recall Menu Mode #085 [TUNER/ATAS], and then rotate the Main Dial to change the setting to "TUNER."
 - h. Press and hold the [FUNC] or [F] key for one second to save the new settings and exit to normal operation.
4. Turn the radio off. Insert the 8-pin modular plug into the tuner's RADIO INTERFACE jack.
5. **Important:** *Make sure the DC power to the radio has been turned off. The radio does not fuse the DC power to the tuner, and damage to the radio can occur if the interface's power connection comes in contact with ground.*
6. Connect the 8-pin mini DIN connector to the mating 8-pin mini DIN connector, marked as CAT/LINEAR, on the back of the radio.
7. Connect a 12V 1.5 amp DC source to the MFJ-998.
8. Push the [POWER] button on the tuner to the *in* position and then power on the radio.

Operation for FT-857 or FT-897

The operation of the MFJ-5114Y radio interface is similar to the operation of the FC-30 described in the Yaesu radio's operating manual.

1. Press the [FUNC] or [F] key, then rotate the [SELECT] or [MEM/VFO CH] knob to recall Multi Function Row "k" [TUNE, DOWN, UP].
2. Press the [A](TUNE) key on the radio to turn the external tuner function on; the "TUNE" or "TUNR" icon will appear in the radio's display.
3. Press and hold the [A](TUNE) key on the radio to begin automatic tuning. The radio will automatically transmit a low-power carrier and start the tuning process. Press the [A](TUNE) key again to cancel tuning in progress. When tuning is completed, the radio will stop transmitting and you will be ready for operation on this frequency.

Note the [TUNE] button on the tuner will not operate the MFJ-5114Y Yaesu radio interface.

Connections for FT-950

1. Select **YAESU FC-30** in the tuner's Radio Interface setup menu. Turn the tuner off.
2. Make sure jumper JP1 inside the MFJ-998 is installed.
3. Before connecting the MFJ-5114Y to your radio, follow the instructions in the radio's manual for installing the FC-40 automatic antenna tuner.
 - a. Press the [MENU] button momentarily to enter the Menu mode.
 - b. Rotate the [SELECT] knob to select Menu item [110 TGEN EXT TUN]. Press the [SELECT] knob momentarily to toggle the display between [110 TGEN] and [EXT TUN].
 - c. Rotate the [CLAR/VFO-B] knob to change the setting to "Etu" to enable the External Tuner.
 - d. Press and hold the [MENU] button for one second to save the new setting and exit to normal operation. If you only *momentarily* press the [MENU] button, the new setting will not be retained.
4. Turn the radio off. Insert the 8-pin modular plug into the tuner's RADIO INTERFACE jack.
5. **Important:** *Make sure the DC power to the radio has been turned off. The radio does not fuse the DC power to the tuner, and damage to the radio can occur if the interface's power connection comes in contact with ground.*
6. Connect the 8-pin mini DIN connector to the mating 8-pin mini DIN connector, marked as TUNER, on the back of the radio.
7. Connect a 12V 1.5 amp DC source to the MFJ-998.
8. Push the [POWER] button on the tuner to the *in* position and then power on the radio.

Operation for FT-950

The operation of the MFJ-5114Y radio interface is similar to the operation of the FC-40 described in the Yaesu radio's operating manual.

1. Press the (TUNE) button on the radio briefly to enable the external tuner function. The "TUNER" icon will appear in the radio's display.
2. Press and hold the (TUNE) button on the radio for one second to begin automatic tuning. The radio will automatically transmit a low-power carrier and start the tuning process. The "TUNER" icon will blink while tuning is in progress. Press the (TUNE) button on the radio while tuning is in progress to cancel the automatic tuning.

Note: *The FT-950 will not start automatic tuning when the SWR is greater than approximately 5:1, indicated by both "TUNER" and "HI-SWR" icons blinking once when the (TUNE) button on the radio is pressed and held for one second.*

3. When tuning is completed, the radio will stop transmitting and you will be ready for operation on this frequency.

Note the [TUNE] button on the tuner will not operate the MFJ-5114Y Yaesu radio interface.

Yaesu Radio Interface/MFJ-5114Y3

The MFJ-5114Y3 radio interface allows users of Yaesu FT-1000MP series, FT-2000 series, and FTDX-9000 series transceivers to connect to the MFJ-998 *IntelliTuner*™ Automatic Antenna Tuner. With this interface, control signals are connected between the radio and the tuner. With this cable the operator can control the tuner and radio with a single push of the [TUNE] button on the front panel of the MFJ-998.

Connections for FT-1000MP series of radios

1. Select **YAESU MP/2K/9K** in the tuner's Radio Interface setup menu. Turn the tuner off.
2. Before connecting the MFJ-5114Y3 to your radio, set the maximum TUNE power of the radio as follows:
 - a. On your transceiver, enter the Menu mode by pressing and holding the [FAST] key and then pressing [ENT].
 - b. Rotate the [MEM/VFO CH] knob until you see menu 4-3 on the transceiver's CH display.
 - c. Rotate the [MAIN VFO] knob to select 50 for 100-watt radios (FT-1000MP/MP Field) or 75 for the FT-1000MP MKV when an amplifier will be used. This gives the best SWR accuracy, which may be important for solid-state amplifiers. When an amplifier is not used, the setting can be set at 10 for all transceivers.
 - d. Press [ENT] to exit the Menu mode.
3. Insert the 8-pin modular plug into the MFJ-998 RADIO INTERFACE jack.
4. Connect the 3.5-mm mono plug on the MFJ-5114Y3 to the REMOTE jack on the rear panel of the transceiver.
5. Connect a 12V 1.5 amp DC source to the MFJ-998.
6. Push the [POWER] button on the MFJ-998 to the *in* position. The radio may be powered on either before or after the tuner is powered on.

Operation for FT-1000MP series of radios

The transceiver is controlled by the MFJ-998. To operate:

1. Press the [TUNE] button on the MFJ-998 for ½-2 seconds to initiate the tuning process. The radio will automatically transmit a low-power carrier and start the tuning process. When tuning is completed, the radio will stop transmitting and you will be ready for operation on this frequency.

Connections for FT-2000 series of radios

1. Select **YAESU MP/2K/9K** in the tuner's Radio Interface setup menu. Turn the tuner off.
2. Before connecting the MFJ-5114Y3 to your radio, set the maximum TUNE power of the radio as follows:
 - a. On your transceiver, enter the Menu mode by pressing the [MENU] key momentarily.
 - b. Rotate the Main Tuning Dial knob until you see menu item [145 tGen TUN PWR] on the transceiver's display.
 - c. Rotate the [SUB VFO-B] knob to select 20 watts for best SWR accuracy. For the FT-2000D, we recommend that this be set to 50 watts if the user normally operates at 100 watts output

- power (when power is turned down to 100 watts, the TUNE power will reduce to 25 watts). If the operator normally has his FT-2000D set for the full 200 watts, then this should be set to 20 watts.
- d. Press and hold in the [MENU] key for two seconds to save the new setting and exit to normal operation. If you press the [MENU] key momentarily, the new setting will not be saved.
3. Insert the 8-pin modular plug into the MFJ-998 RADIO INTERFACE jack.
 4. Connect the 3.5-mm mono plug on the MFJ-5114Y3 to the REM (REMOTE) jack on the rear panel of the transceiver.
 5. Connect a 12V 1.5 amp DC source to the MFJ-998.
 6. Push the [POWER] button on the MFJ-998 to the *in* position. The radio may be powered on either before or after the tuner is powered on.

Operation for FT-2000 series of radios

The transceiver is controlled by the MFJ-998. To operate:

1. Press the [TUNE] button on the MFJ-998 for ½-2 seconds to initiate the tuning process. The radio will automatically transmit a low-power carrier and start the tuning process. When tuning is completed, the radio will stop transmitting and you will be ready for operation on this frequency.

Connections for FTdx-9000 series of radios

1. Select ~~YAESU MP/2K/9K~~ in the tuner's Radio Interface setup menu. Turn the tuner off.
2. Before connecting the MFJ-5114Y3 to your radio, set the maximum TUNE power of the radio as follows:
 - a. On your transceiver, enter the Menu mode by pressing the [MNU] key momentarily.
 - b. Rotate the Main Tuning Dial knob until you see menu item [157 EXT AMP TUNING PWR] on the transceiver's display.
 - c. Rotate the [CLAR/VFO-B] knob to select 50 watts for best SWR accuracy. The TUNE power varies with the output power level control setting, so ensure that the TUNE power is somewhere between 20-50 watts.
 - d. Press and hold in the [MNU] key for two seconds to save the new setting and exit to normal operation. If you press the [MNU] key momentarily, the new setting will not be saved.
3. Insert the 8-pin modular plug into the MFJ-998 RADIO INTERFACE jack.
4. Connect the 3.5-mm mono plug on the MFJ-5114Y3 to the REMOTE jack on the rear panel of the transceiver.
5. Connect a 12V 1.5 amp DC source to the MFJ-998.
6. Push the [POWER] button on the MFJ-998 to the *in* position. The radio may be powered on either before or after the tuner is powered on.

Operation for FTDX-9000 series of radios

The transceiver is controlled by the MFJ-998. To operate:

1. Press the [TUNE] button on the MFJ-998 for ½-2 seconds to initiate the tuning process. The radio will automatically transmit a low-power carrier and start the tuning process. When tuning is completed, the radio will stop transmitting and you will be ready for operation on this frequency.

Yaesu Radio Interface/MFJ-5114Y4

The FT-2000 series radio has a TX REQ input on the back that can be used in lieu of the REM (REMOTE) input. If this option is chosen, you must use the MFJ-5114Y4 radio interface cable. With this interface, control signals are connected between the radio and the tuner. With this cable the operator can control the tuner and radio with a single push of the [TUNE] button on the front panel of the MFJ-998.

Connections for FT-2000 series of radios

1. Select `YAESU MF/2K/9K` in the tuner's Radio Interface setup menu. Turn the tuner off.
2. Before connecting the MFJ-5114Y4 to your radio, set the maximum TUNE power of the radio as follows:
 - a. On your transceiver, enter the Menu mode by pressing the [MENU] key momentarily.
 - b. Rotate the Main Tuning Dial knob until you see menu item [145 tGEN TUN PWR] on the transceiver's display.
 - c. Rotate the [SUB VFO-B] knob to select 20 watts for best SWR accuracy. For the FT-2000D, we recommend that this be set to 50 watts if the user normally operates at 100 watts output power (when power is turned down to 100 watts, the TUNE power will reduce to 25 watts). If the operator normally has his FT-2000D set for the full 200 watts, then this should be set to 20 watts.
 - d. Press and hold in the [MENU] key for two seconds to save the new setting and exit to normal operation. If you press the [MENU] key momentarily, the new setting will not be saved.
3. Insert the 8-pin modular plug into the MFJ-998 RADIO INTERFACE jack.
4. Connect the RCA plug on the MFJ-5114Y4 to the TX REQ jack on the rear panel of the transceiver.
5. Connect a 12V 1.5 amp DC source to the MFJ-998.
6. Push the [POWER] button on the MFJ-998 to the *in* position. The radio may be powered on either before or after the tuner is powered on.

Operation for FT-2000 series of radios

The transceiver is controlled by the MFJ-998. To operate:

1. Press the [TUNE] button on the MFJ-998 for ½-2 seconds to initiate the tuning process. The radio will automatically transmit a low-power carrier and start the tuning process. When tuning is completed, the radio will stop transmitting and you will be ready for operation on this frequency.

In Case of Difficulty

If the LCD screen is blank, check adjustment of the contrast control. If no audio is present (with audio enabled) adjust the volume control.

If the tuner acts erratic, reset the tuner to factory defaults by pressing both the [TUNE] and [L-UP] buttons while turning the power on.

If the tuner fails to tune, please **double check** all connections and follow the tuning procedures again. Be sure you are using *enough inductance* (through manual adjustment) and *minimum capacitance*.

If the tuner arcs at the rated power levels, please **double check** all connections and follow the tuning procedures again. Ensure you are not exceeding the tuner's rated power handling capability. Be sure you are using the *least amount of inductance* and the *greatest capacitance* possible that still allows matching the load on the operating frequency.

Note: *If the tuner arcs when operating on the 160-meter band, it may be necessary to reduce transmitter output power.*

If you are still unsuccessful, but the tuner does adjust and operate when used with a dummy load or another antenna, please read “Grounding Hints” and “Antenna System Hints” on page 25.

Technical Assistance

If you have any problem with this unit first check the appropriate section of this manual. If the manual does not reference your problem or your problem is not solved by reading the manual, you may call *MFJ Technical Service* at 662-323-0549 or the *MFJ Factory* at 662-323-5869. You will be best helped if you have your unit, manual and all information on your station handy so you can answer any questions the technicians may ask.

You can also send questions by mail to MFJ Enterprises, Inc., 300 Industrial Park Road, Starkville, MS 39759; by facsimile (FAX) to 662-323-6551; or by email to techinfo@mfjenterprises.com. Send a complete description of your problem, an explanation of exactly how you are using your unit, and a complete description of your station. Also include the firmware version number of your unit.

List of Accessories

- **MFJ-912:** 1.5 kW 4:1 balun
- **MFJ-1316:** 12 VDC 1.5 amp power supply
- **MFJ-5114A:** Interface cable for compatible Alinco radios
- **MFJ-5114I:** Interface cable for compatible Icom radios
- **MFJ-5114K:** Interface cable for compatible Kenwood radios
- **MFJ-5114Y:** Interface cable for Yaesu FT-100, FT-450, FT-857, FT-897, and FT-950
- **MFJ-5114Y3:** Interface cable for Yaesu FT-1000MP series, FT-2000 series, and FTDX-9000 series
- **MFJ-5114Y4:** Interface cable for Yaesu FT-2000 series (use TX REQ input instead of REM input)
- **MFJ-5409:** 6' RS-232 cable, female DB-9 to male DB9 connector
- **MFJ-5803:** 3' RG-58 50-ohm coax cable with PL-259 connectors on each end (tuner input only)
- **MFJ-5806:** 6' RG-58 50-ohm coax cable with PL-259 connectors on each end (tuner input only)
- **MFJ-5818:** 18' RG-58 50-ohm coax cable with PL-259 connectors on each end (tuner input only)

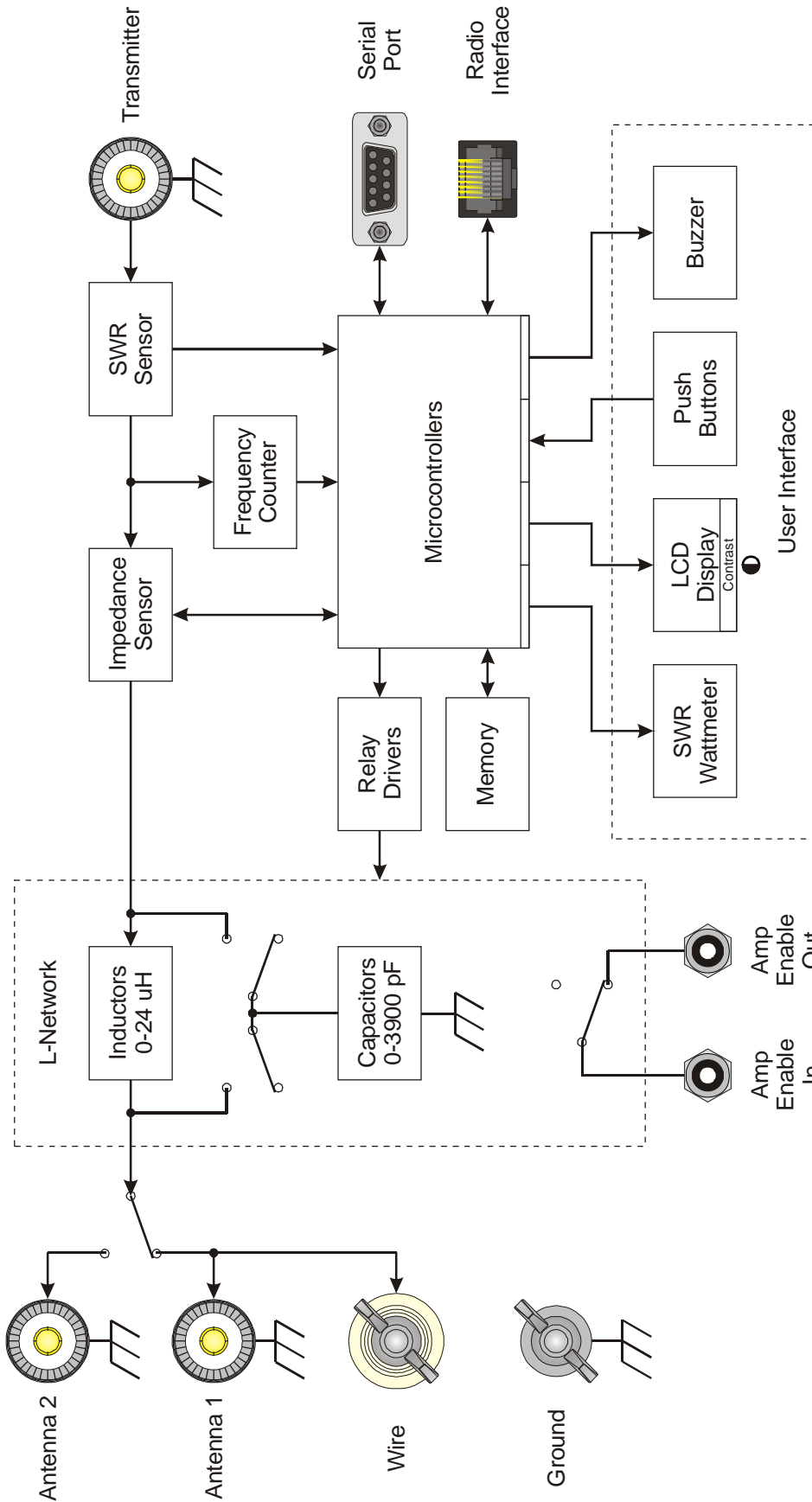

Figure 19. MFJ-998 Circuit Block Diagram.

LIMITED 12 MONTH WARRANTY

MFJ Enterprises, Inc. warrants to the original owner of this product, if manufactured by MFJ Enterprises, Inc. and purchased from an authorized dealer or directly from MFJ Enterprises, Inc. to be free from defects in material and workmanship for a period of 12 months from date of purchase provided the following terms of this warranty are satisfied.

1. The purchaser must retain the dated proof-of-purchase (bill of sale, canceled check, credit card or money order receipt, etc.) describing the product to establish the validity of the warranty claim and submit the original or machine reproduction of such proof of purchase to MFJ Enterprises, Inc. at the time of warranty service. MFJ Enterprises, Inc. shall have the discretion to deny warranty without dated proof-of-purchase. Any evidence of alteration, erasure, or forgery shall be cause to void any and all warranty terms immediately.
2. MFJ Enterprises, Inc. agrees to repair or replace at MFJ's option without charge to the original owner any defective product under warrantee provided the product is returned postage prepaid to MFJ Enterprises, Inc. with a personal check, cashiers check, or money order for **\$10.00** covering postage and handling.
3. This warranty is **NOT** void for owners who attempt to repair defective units. Technical consultation is available by calling the Service Department at 662-323-0549 or the MFJ Factory at 662-323-5869.
4. This warranty does not apply to kits sold by or manufactured by MFJ Enterprises, Inc.
5. Wired and tested PC board products are covered by this warranty provided **only the wired and tested PC board product is returned**. Wired and tested PC boards installed in the owner's cabinet or connected to switches, jacks, or cables, etc. sent to MFJ Enterprises, Inc. will be returned at the owner's expense unrepaired.
6. Under no circumstances is MFJ Enterprises, Inc. liable for consequential damages to person or property by the use of any MFJ products.
7. **Out-of-Warranty Service:** MFJ Enterprises, Inc. will repair any out-of-warranty product provided the unit is shipped prepaid. All repaired units will be shipped COD to the owner. Repair charges will be added to the COD fee unless other arrangements are made.
8. This warranty is given in lieu of any other warranty expressed or implied.
9. MFJ Enterprises, Inc. reserves the right to make changes or improvements in design or manufacture without incurring any obligation to install such changes upon any of the products previously manufactured.
10. All MFJ products to be serviced in-warranty or out-of-warranty should be addressed to:

MFJ Enterprises, Inc.
300 Industrial Park Road
Starkville, Mississippi 39759 USA

and must be accompanied by a letter describing the problem in detail along with a copy of your dated proof-of-purchase.

11. This warranty gives you specific rights, and you may also have other rights which vary from state to state.



MFJ ENTERPRISES, INC.
300 Industrial Park Road
Starkville, MS 39759

MFJ-998 Manual
Version 1F
Printed In U.S.A. 07/2010